

## PERFORMANCE AND EMISSION STUDIES ON DI-DIESEL ENGINE FUELED WITH PONGAMIA METHYL ESTER INJECTION AND METHANOL CARBURETION

HARIBABU, N.<sup>1,\*</sup>, APPA RAO, B.V.<sup>2</sup>, ADINARAYANA, S.<sup>3</sup>,  
SEKHAR, Y.M.C.<sup>4</sup>, RAMBABU, K.<sup>5</sup>

<sup>1</sup>Aditya Institute of Technology and Management, Tekkali-532201, Srikakulam  
Dist- Andhra Pradesh, India

<sup>2</sup>Department of Marine Engg, A.U. College of Engineering (A), Andhra University,  
Visakhapatnam, India.

<sup>3,4</sup>Department of Mechanical Engg., MVGR College of Engineering, Vizianagaram-5. India

<sup>5</sup>Sir CR Reddy College of Engineering, Eluru, 534007, W.G.(Dst), A.P, India

\* Corresponding Author: haribabunethala@gmail.com

### Abstract

The target of the present study is to clarify ignition characteristics, combustion process and knock limit of methanol premixture in a dual fuel diesel engine, and also to improve the trade-off between NO<sub>x</sub> and smoke markedly without deteriorating the high engine performance. Experiment was conducted to evaluate the performance and emission characteristics of direct injection diesel engine operating in dual fuel mode using Pongamia methyl ester injection and methanol carburetion. Methanol is introduced into the engine at different throttle openings along with intake air stream by a carburetor which is arranged at bifurcated air inlet. Pongamia methyl ester fuel was supplied to the engine by conventional fuel injection. The experimental results show that exhaust gas temperatures are moderate and there is better reduction of NO<sub>x</sub>, HC, CO and CO<sub>2</sub> at methanol mass flow rate of 16.2 mg/s. Smoke level was observed to be low and comparable. Improved thermal efficiency of the engine was observed.

Keywords: PME, Methanol, Carburetion, Performance, Emissions.

### 1. Introduction

The use of alternative fuels for internal combustion engines has attracted a great deal of attention due to the fossil fuel crisis and concern to produce prime movers with acceptable emission characteristics. This situation has stimulated active

research interest on non-polluting fuels for diesel engines, particularly in the fields like heavy transportation and agriculture. Vegetable oils offer the advantage of freely mixing with alcohols and these blends can be used in the existing diesel engines without modifications. It is also a simple process. Blending of vegetable oils with methanol results in significant improvement in their physical properties. It is reported that the viscosity and density are considerably reduced.

Vegetable oils in varying proportions in the fuel blend were tried by a number of investigators. Results obtained from the experiments on a diesel engine using a blend of vegetable oil and alcohol showed improved brake thermal efficiency and reduced exhaust smoke emissions than neat vegetable oils [1, 2]. However, the maximum quantity of alcohol that can be blended is limited by the presence of water in alcohol. High quantities lead to separation.

Dual fuel approach is a well-established technique to use different types of fuels in diesel engines. A conventional diesel engine can be easily modified to operate in this mode. This engine can accept a wide range of liquid and gaseous fuels as the primary energy source [3, 4]. In a dual fuel engine, a volatile fuel with a high octane number is inducted along with air through the intake manifold and is ignited by injecting a small quantity of diesel called the pilot fuel. Alcohols can be used as inducted fuels in dual fuel operation. Since vegetable oils produce high smoke emissions, dual fuel approach can be a viable option for improving their performance. Vegetable oils can be used as the pilot fuel and alcohol can be the inducted fuel. The high flame velocity of alcohols will also improve the overall combustion process. Diesel engines with all their advantages suffer from the problems of high smoke and particulate emission. Apart from hydrocarbons and carbon monoxide emissions are also considered as important emissions from diesel engines [5].

To meet extremely stringent emission standards in an automotive engine, extensive researches have been carried out to explore various ways to reduce NO<sub>x</sub> and particulate emissions from diesel engines. In various methods for reducing both NO<sub>x</sub> and smoke in diesel engines, natural gas [6], dimethyl-ether [7, 8], methanol [9], and Fischer-Tropsch diesel fuel [10] have been utilized as alternative fuels for low emission diesel engines.

Ishida et al. [11] in their work injected methanol into the suction port of each cylinder in an ordinary direct injection diesel engine, and was ignited by a small amount of gas oil as an ignition source. The effects of the equivalence ratio of methanol, the injection amount and the injection timing of gas oil, the intake temperature and the compression ratio on ignition, the maximum burning rate of methanol mixture and the knock limit were investigated experimentally. It is found that the maximum burning rate of methanol is almost independent on the intake temperature until knock onset. As results, a marked improvement in the trade-off between NO<sub>x</sub> and smoke was achieved maintaining a high thermal efficiency by a suitable combination between the parameters mentioned above for each engine load further adopting the high EGR rate and the small orifice size nozzle as well.

Dual fuel operation offers reduced smoke and emissions with improved performance. In this dual fuel operation methanol is inducted along with air through carburetor and ignited by injecting neat Pongamia methyl ester.

## 2. Materials and Methods

The experimental setup used for these investigations, which is consisting of DI-diesel engine with carburetor at the bifurcated air inlet, is shown in Fig. 1. The schematic diagram of the experimental set up is shown in Fig. 1(b). Methanol (heated to temperatures in between 40°-50°C) is carbureted at the suction end through a bifurcated air duct along with the Pongamia methyl ester injection. The amount of methanol is regulated through the throttle opening of the carburetor and the engine performance was tested at three different throttle openings. Different mass flow rates of methanol is inducted to eliminate the knocking condition; 37.9 mg/s, 23.2 mg/s, 16.2 mg/s were implemented at the three different throttle openings. 37.9 mg/s mass flow is maximum flow rate after which knocking becomes severe which can be observed through the sudden power loss of the engine. Throttle opening more than this is forfeited. Experimentation is carried out at various engine loads by means of eddy current dynamometer. Engine performance data is acquired to investigate engine performance along with the engine pollution parameters.

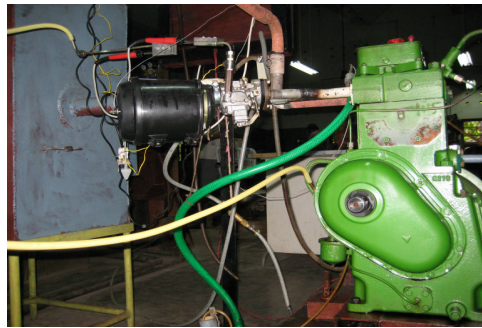

Fig. 1(a). Diesel Engine with Carburetor at the Bifurcated Air Inlet.

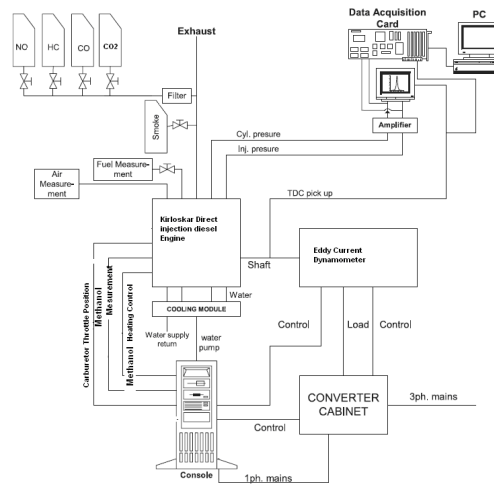

Fig. 1(b). Schematic Diagram of Experimentation.

### 3. Engine, Pollution Measurement, and Fuel Specifications

#### 3.1. Engine details

The engine details are given in Table 1.

**Table 1. Specifications for Kirlosker Diesel Engine.**

<b>Rated Horsepower</b>	5	hp
<b>Rated Speed</b>	1500	rpm
<b>No of Strokes</b>	4	
<b>Mode of Injection</b>	DI	
<b>No of Cylinders</b>	1	
<b>Bore</b>	80	mm
<b>Stroke</b>	110	mm
<b>Compression ratio</b>	16.5:1	

#### 3.2. Pollution measurement

MRU exhaust gas analyzer, Delta 1600-L calibrated with propane is used to measure the pollution caused by the engine.

#### 3.3. Fuel properties

Table 2 shows the properties of PME and methanol.

**Table 2. Properties of PME and Methanol (Estimated at Hindustan Petroleum and Chemicals Limited, Visakhapatnam, A.P., India)**

<b>Fuel sample properties</b>	<b>PME</b>	<b>Methanol</b>
<b>Density at 33°C, (kg/m<sup>3</sup>)</b>	873	790
<b>Gross Calorific Value, (kJ/kg)</b>	38,874	20,000
<b>Viscosity at 33°C, (cSt.)</b>	4.56	0.66
<b>Cetane Number</b>	50	3
<b>Rams bottom Carbon Residue, wt%</b>	0.36	0
<b>Flash Point, °C</b>	170	11
<b>Density at 33°C, (kg/m<sup>3</sup>)</b>	873	790

### 4. Results and Discussion

Figure 2 shows that because of energy supplementation from the methanol specific fuel consumption of PME has decreased with the increase of load and increased with the decrease of methanol flow rates from 37.9 mg/s to 16.2 mg/s. It also shows that the PME consumption is increasing at higher loads with the decrease of methanol flow rate but compared to neat PME specific fuel consumption of PME is lesser for the methanol flow rate of 16.2 mg/s at all loads but for at full load with a marginal increase. Unfair utilization of methanol is observed at higher loads for the flow rates of 10.8, 13.8, 16.2 mg/s since SFC is more than when the neat PME is used as shown.

Figures 3 and 4 show that brake thermal efficiency has increased with the increase of methanol equivalence ratio and with respect to load. Increase of methanol flow rate from 16.2 mg/s to 37.9 mg/s increased the thermal efficiency by

1.65 % at 0.25 full load and by 1.8 % at full load. Thermal efficiency of Pongamia methyl ester is remaining low at 14% where as at 0.25 full load and at full load it has reached to a height of around 27%. High speed flame of methanol in combustion might be the reason for the steep increase in thermal efficiency. At higher loads the negative effect in SFC with the lower methanol flow rates is reflected in the thermal efficiency curves also. Thermal efficiency suffered marginally in this higher load zones because of non utilization of methanol presence for effective combustion. Incomplete combustion can be assessed from the HC and CO emissions also at these loads and alcohol flow rates (Figs. 6-9). Diesel fuel yielded lowest thermal efficiency but it proved better at higher loads than the dual fuel combinations with methanol flow rates 10.8, 13.8, 16.2 mg/s as shown in Fig. 4.

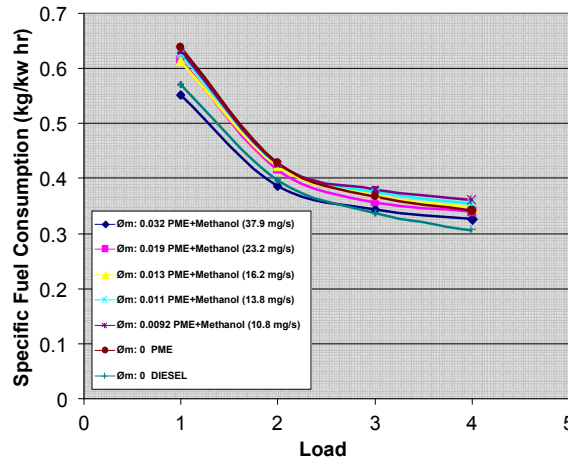

Fig. 2. Variation of Specific Fuel Consumption with Load on the Engine.

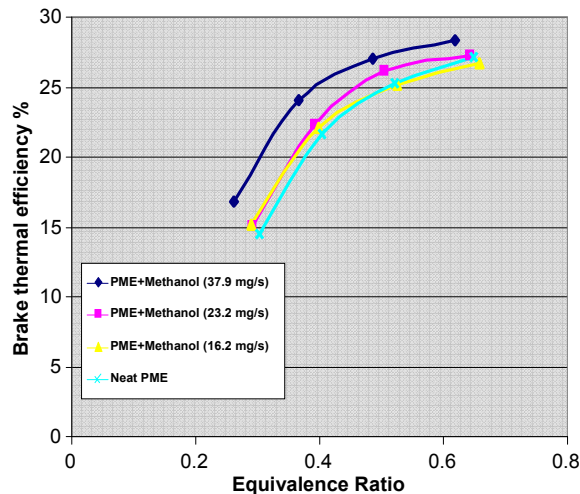

Fig. 3. Variation of Brake Thermal Efficiency with Equivalence Ratio for Pongamia Methyl Ester.

From the research survey the exhaust gas temperature increase is there with the implementation of biodiesel which is reflecting in these measurements also. Addition of methyl alcohol decreased very marginally and this is because of low temperature combustion involving methanol (Fig. 5).

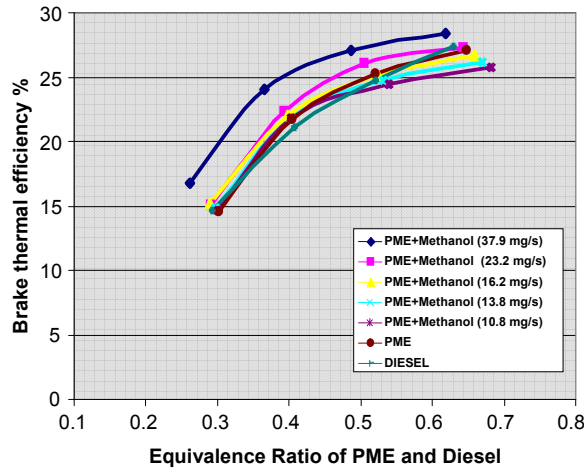

Fig. 4. Variation of Brake Thermal Efficiency with Load for Methanol Equivalence Ratio of PME and Diesel.

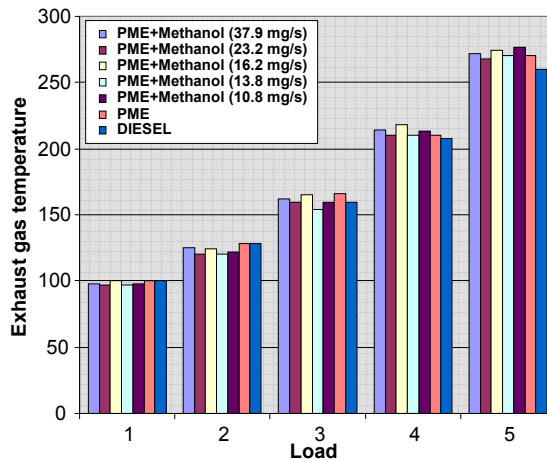

Fig. 5. Variation of Exhaust Gas Temperatures with Load.

The HC emission has increased with the dual fuel operation (Fig. 6). The HC emission of neat PME and diesel fuel operation maintained minimum through out at all loads when compared to the PME and Methanol combinations. The higher HC emission is observed at lower loads when the methanol induction is higher and recorded maximum (450 ppm) at no load operation because of flame quenching due to cold combustion.

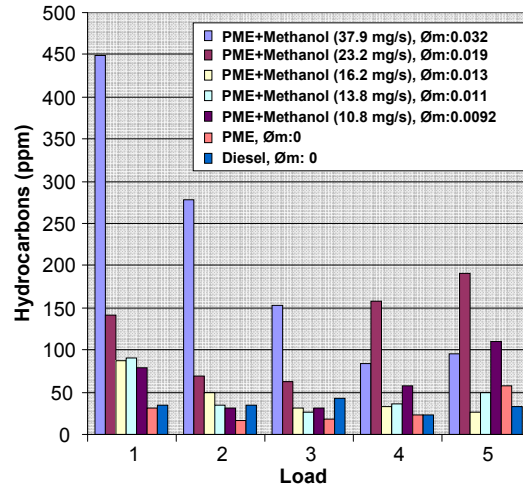

Fig. 6. Variation of Hydrocarbons with Load.

Increase in NO emission with the increase of load is observed for neat PME and also PME, methanol combinations. The NO emission for the Methanol mass flow 16.2 mg/s is minimum i.e. 605 ppm at full load operation and again increased with the decrease of methanol flow rate as shown in Fig. 7. It is a known fact that biodiesel produces more NO than the Petro diesel. Higher flame velocities also produce higher NO and that happens in case of dual fuel operation. The mass flow rate 16.2 mg/s stands more beneficial methanol flow rate at all loads and this may be acclaimed to better mixing due to the methanol flame propagation and combustion temperature control.

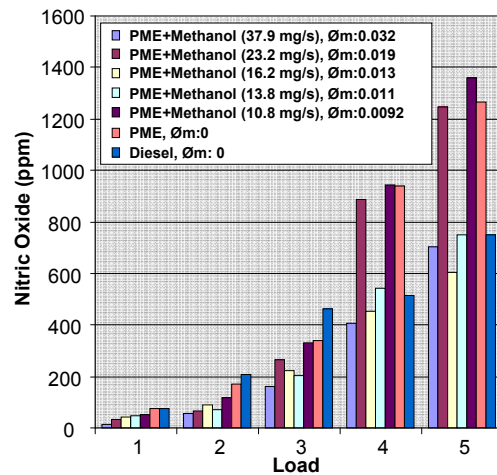

Fig. 7. Variation of Nitric Oxide with Load.

CO emission is least for methanol mass flow 16.2 mg/s. With this combination the values ranging from 0.04% to 0.03% at no load to full load gives best reduction with respect to neat PME (Fig. 8). CO emission for the low temperature combustion will be more but for the flow rate of 16.2mg/s and its

neighbouring flow rate 13.8 mg/s remained efficient in controlling the combustion. CO emission levels have fallen when compared to diesel and biodiesel. The flame speeds, entrainment and inside the combustion zone heat transfer levels may have been encouraging to make combustion efficient.

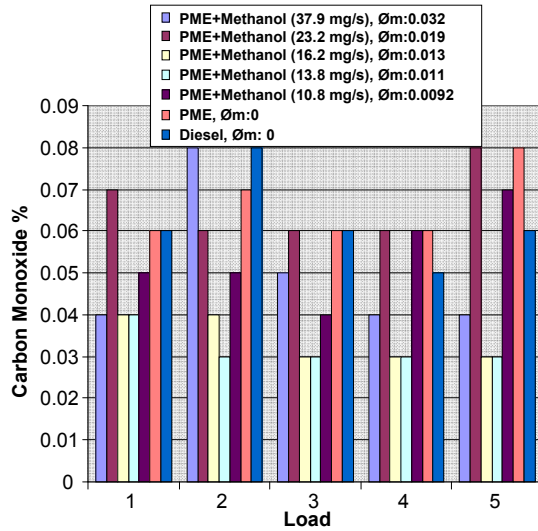

Fig. 8. Variation of Carbon Monoxide % with Load.

CO<sub>2</sub> emission is lesser in the PME and methanol combinations than but methanol flow 37.9 mg/s gives higher value at no load condition and methanol flow 23.2 mg/s gives highest value at full load (Fig. 9). The methanol flow rate of 16.2 mg/s is again the best one in controlling the combustion and reducing the CO<sub>2</sub> emission.

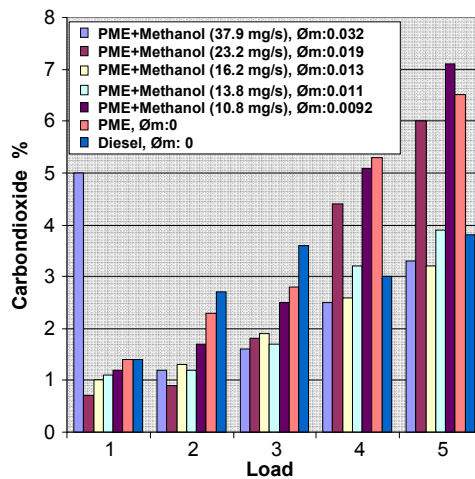

Fig. 9. Variation of Carbon Dioxide % with Load.

Free air (lambda), O<sub>2</sub> emissions are also reasonably more (Figs.10 and 11). At maximum loads, when compared to neat PME free air and oxygen emissions are low.



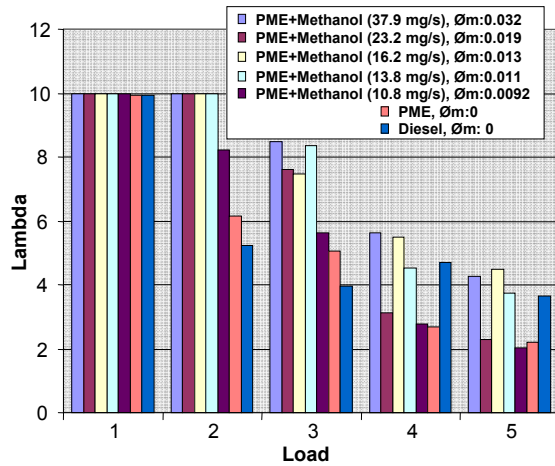

Fig. 10. Variation of Lambda with Load.

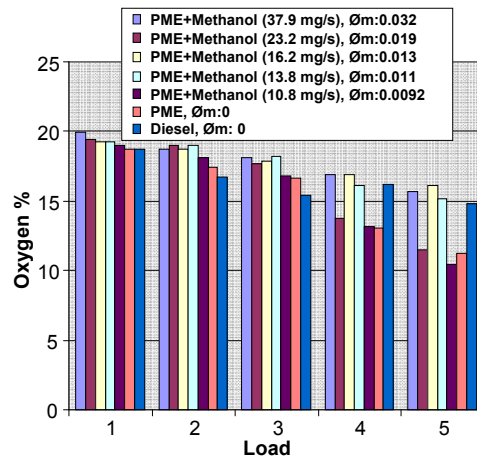

Fig. 11. Variation of Oxygen % with Load.

Smoke emission is comparable with neat PME applications (Fig.12). Smoke emission is more when methanol flow rate 37.9 mg/s at all loads. This is due to low temperature combustion generated by the induction of methanol. Cold combustion effect prevails in most of the methanol combinations and the flow rate in the vicinity of 16.2 mg/s i.e. 13.8 mg/s is reducing smoke at part loads.

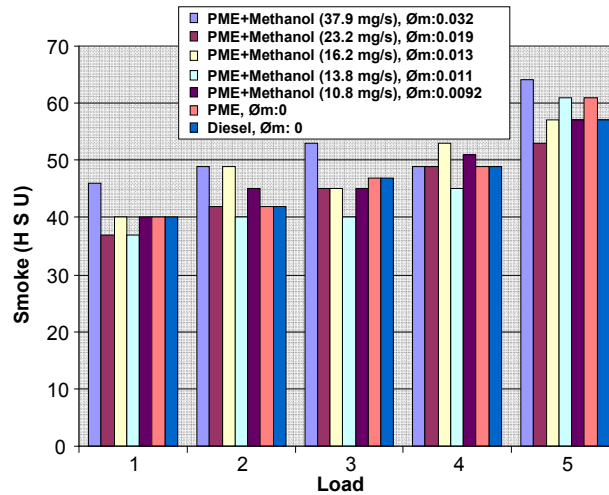

Fig. 12. Variation of Smoke Intensity with Load.

## 5. Conclusions

- The PME consumption is increasing with the decrease of methanol flow rate but compared to neat PME specific fuel consumption is lesser except for the case of 16.2 mg/s methanol induction at full load.
- Addition of methyl alcohol decreased very marginally and this is because of low temperature combustion involving methanol
- Increased flow rate of methanol along with the PME has improved the thermal efficiency of the engine in general but for at some occasions.
- The fuel combination containing 16.2 mg/s mass flow of methanol induction can be concluded as the best PME and methanol combination based on the reduction in exhaust emissions like NO, HC, and CO.
- Free air and Oxygen emissions are comparatively more.
- Cold combustion effect prevails in most of the methanol combinations and the flow rate in the vicinity of 16.2mg/s i.e. 13.8mg/s is reducing smoke at part loads.
- High speed combustion of methanol and higher latent heat fetch some advantages in controlling combustion and emissions.

## Acknowledgment

The author thanks Prof. B.V. Appa Rao, Department of Marine Engineering, Andhra University, Visakhapatnam for the unstinted support in guiding my research in this field.

## References

1. Basker T. (1993). *Experimental Investigation on the use of vegetable oil and vegetable oil esters in a low heat injection engine*. M.Sc. thesis, I.C.E. lab, IIT Madras-36.
2. Murayama, T.; Oh, Y.; Miyamoto, N.; Chikahisa, T.; Takagi, N.; and Itow, K. (1984). Low carbon flower buildup, low smoke, and efficient diesel operation with vegetable oils by conversion to mono-esters and blending with diesel oils or alcohols. *SAE*, Paper No. 841161.
3. Karim, G.A.; and Amoozegar, N. (1983). Determination of the performance of a dual fuel diesel engine with addition of various liquid fuels to the intake charge. *SAE*, Paper No. 830265.
4. Naeser, D.; and Bennet, K.F. (1980). The operation of dual fuel compression ignition engines utilizing diesel and methanol. *Proceedings of the IV International Symposium on Alcohol Fuels Technology*, Brazil, 1980.
5. Kumar, M.S.; Ramesh, A.; and Naglingam, B. (2003). An experimental comparison of methods to use methanol and jatropha oil in a compression ignition engine. *Biomass and Bioenergy*, 25(3), 309- 318.
6. Agarwal, A.; and Assanis, D., (2000). Multi-dimensional modeling of ignition, combustion and nitric oxides formation in direct injection natural gas engines. *SAE*, Paper No. 2000-01-1839.
7. Kajitani, S.; Zhili, C., Z.; Konno, M.; and Rhee, K.T. (1997). Engine performance and exhaust characteristics of direct injection diesel engine operated with DME. *SAE*, Paper No. 972973.
8. Kajitani, S.; Oguma, M.; and Mori, T. (2000). DME fuel blends for low-emission, direct-injection diesel engines. *SAE*, Paper No. 2000-01-2004.
9. Ishida, M.; Ueki, H.; Sakaguchi, D.; and Imaji, H. (1999). Simultaneous reduction of NOx and smoke by port injection of methanol/water blend in a DI diesel engine. In: *Proceedings of 15th Internal Combustion Engine Symposium (International)*, Seoul, Paper No. 9935202, 93-98.
10. Johnson, W.J.; Berlowitz, P.J.; Ryan, D.F.; Wittenbrink, R.J.; Genetti, W.B.; Ansell, L.L.; Kwon, Y.; and Rickeard, D.J. (2001). Emissions from Fischer-Tropsch diesel fuels. *SAE*, Paper No. 2001-01-3518.
11. Masahiro, Ishida; Tetsuya, Tagai; Hironobu, Ueki; and Daisaku, Sakaguchi. (2004). Ignition and combustion characteristics of methanol mixture in a dual fuel diesel engine (Diesel engines, performance and emissions, intake gas treatment). The international symposium on diagnostics and modeling of combustion in internal combustion engines. *CiNii Journal*, 6, 51-58.