

DEVELOPMENT OF SMALL INJECTION MOULDING MACHINE FOR FORMING SMALL PLASTIC ARTICLES FOR SMALL-SCALE INDUSTRIES

OYETUNJI, A.

Department of Metallurgical and Materials Engineering,
The Federal University of Technology, Akure, Ondo State, Nigeria.
Email: akinlabioyetunji@yahoo.com

Abstract

Development of small injection moulding machine for forming small plastic articles in small-scale industries was studied. This work which entailed design, construction and test small injection moulding machine that was capable of forming small plastic articles by injecting molten resins into a closed, cooled mould, where it solidifies to give the desired products was developed. The machine was designed and constructed to work as a prototype for producing very small plastic components. Design concept, operation, and assembly of components parts were made. Also, working drawings and materials selection were made based on calculations of the diameter of injection plunger, number of teeth required for the plunger rack and spur gear, the angular velocity, number of revolution, torque and power obtained from the electric motor selected and the leverage on the handle of the machine. The machine parts/components were then assembled in line with the designed made, thereafter the constructed machine was tested using high density polyethylene and master batch. The results obtained from the test were satisfactory.

Keywords: Development, Injection, Moulding, Machine, Plastics, Industries.

1. Introduction

Injection moulding machine offers many advantages to alternatives manufacturing methods, including minimal losses from scrap (since scrap pieces can be melted and recycled), and minimal finishing requirements. Injection moulding machine differs from metal die casting, in that molten metal's can simply be poured, and plastic resins must be injected with force [1]. It is most common used method for mass production of plastic articles [2].

Nomenclatures	
d	Diameter of plunger, m
d_l	Distance of the handle from the platen, m
F	Force, N
g	Acceleration due to gravity, m/s^2
l	Length of injection plunger, m
m	Mass of the melt, kg
m_h	Mass of handle, m
N	Number of revolution, rpm
P	Power, W
r	Radius of plunger, m
r_s	Radius of motor shaft, m
T	Torque, Nm
V	Volume of the melt, m^3
v	Injection linear velocity, m/s
<i>Greek Symbols</i>	
ρ	Density of the melt, kg/m^3
ω	Angular velocity, rad/s

The process involves introducing raw materials in form of granules into one end of a heated cylinder, heating the materials in the heating chamber, and forcing the molten metal into a closed mould, where the final solidification of the molten metal in form of the configuration of the mould cavity takes [3].

The intending injection machine will be made from mild steel and medium carbon steel. It can only be used for the production of small components such as key holder, bottle cap, tally, ruler, and clothes peg. The mild steel is used for the construction of supporting plates, hopper, mainframe, mould, and platens, handle, and tie bars. This is because; they are not subjected to constant heat. It is easily weldable, and has good workability but show poor response to heat treatment.

An injection moulding machine is a piece of equipment consists of two basic elements, the injection unit and the clamping unit. Injection moulding can be used with a variety of plastic resins. The chosen resins for this process are polyethylene; polypropylene, ABS, and fluorocarbons, because of characteristics of intricate shapes can easily be produced [4]. The advantages of small injection moulding process include good surface finish of the product can be produced, less scrap and flashes are produced, and the process has relatively low labour costs.

The main aim of the research work is to design, construct and testing of small injection moulding machine while the specific objectives of the research work are to design and construct a small injection moulding machine, and testing. The scope of the work is to design and construct a cost effective and environmentally friendly small injection moulding machine for the production of small plastic articles. The research work will involve design concept, operations, design analysis that will entail design of injection plunger, motor selection, design of the handle, and the leverage on the handle of the machine. Also, assembly drawings of the machine, recommended materials and equipment for the construction of

design machine will be provided to assist investors that want to venture into construction of this machine.

Development of small injection moulding machine for forming small plastic articles in small-scale industries was borne out of the fact that most injection moulding machines were of big size and most small-scale industries in developing countries could not avoid buying them due to their costs. In solving this problem, there is a need to design small injection moulding machine that is avoidable by small scale industries for production of small plastic articles, this is the rationale behind this work.

2. Design Concept and Analysis

This design concept encompasses the following:

- a) Maximum volume of the melt needed to fill the mould. This entails plunger travel (l), diameter of the barrel (d), melt density (ρ_m) and melt mass (m);
- b) Design of barrel which entails diameter of the barrel and maximum piston travel; and
- c) Design for plunger.

While the design analysis entails the following units:

- a) The injection unit comprises of the hopper, barrel, heater bands, nozzle, and injection plunger.
- b) The clamping unit consists of the mould, platens, and the handle known as the locking device.
- c) The electrical panel comprises of temperature control, contactors, thermocouple, heat resistance wire, and knob (control button).

2.1. Design of injection plunger

In the injection plunger design shown in Fig. 1, the volume of the melt (V) the plunger can successfully pushed from the barrel can be determined by knowing the diameter of the plunger. It goes thus:

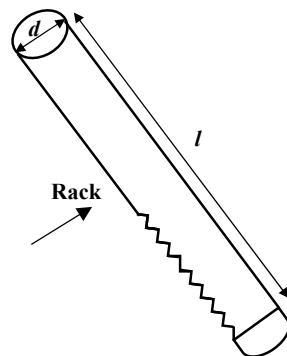

Fig. 1. Injection Plunger.

Using Fig. 1, the diameter of the plunger can be determined from Eq. (1)

$$V = \pi r^2 l \quad (1)$$

$$r = d/2 \quad (2)$$

The expression in Eq. (1) can be expressed in terms of diameter (d),

$$V_1 = \pi \frac{d^2}{4} l \quad (3)$$

Also, volume (V) of the melt in the barrel can be obtained from Eq. (4),

$$V_2 = \frac{\text{mass of the melt, } m}{\text{density of the melt, } \rho} \quad (4)$$

Therefore,

$$V_1 = V_2 \quad (5)$$

This implies that,

$$\pi \frac{d^2}{4} l = \frac{m}{\rho} \quad (6)$$

Making d^2 the subject of expression, we have

$$d^2 = \frac{4m}{\pi \rho l} \quad (7)$$

Therefore, the plunger diameter can be determined from Eq. (7),

$$d = \sqrt{\frac{4m}{\pi \rho l}} \quad (8)$$

Number of teeth required on the plunger rack

The number of teeth required is determined from Eq. (9)

$$\text{Number of teeth required on the plunger rack} = \frac{\text{length of travel expected of plunger}}{\text{circular pitch distance}} \quad (9)$$

Number of teeth required on spur gear (pinion).

The number of teeth required on the spur gear is determined from Eq. (10),

$$\text{Number of teeth required on spur gear} = \frac{\pi \times \text{diameter of pitch circle}}{\text{circular pitch distance}} \quad (10)$$

Motor selection

The angular velocity (ω) can be determined from Eq. (11),

$$\omega = v / r \quad (11)$$

While the number of revolution (N) can be determined from Eq. (12),

$$N = \frac{60\omega}{2\pi} \quad (12)$$

In addition, the torque (T) of the motor can be determined from Eq. (13),

$$T = Fr_s \quad (13)$$

Likewise the power (P) can be determined from Eq. (14),

$$P = T\omega \quad (14)$$

Design of the handle

In the design of the handle, the leverage on the handle (M_L) of the machine can be determined from Eq. (15),

$$M_L = m_h g d_l \quad (15)$$

2.2. Design calculations

In this work the complete design calculations are made. The design calculations include the calculations of the diameter of injection plunger, number of teeth required on the plunger rack, number of teeth required on spur gear (pinion), motor selection, and leverage on the handle. These calculations are based on the mathematical equations shown in Sec. 2.1. The numerical calculations for the selected concept are outlined in *Appendix A*.

3. Methods

When designing the machine, the construction and parts specification, and testing performance are some of the critical procedures that were followed to achieve good results.

3.1. Assembly of machine

The procedures for assembling the machine are as follows:

- fixing the main frame,
- position the supporting plates and bolt them together with the tie bars,
- bolt the barrel to the supporting plate 2,
- mount the plunger assembly through the supporting plates 1 and 2 to the barrel,
- positioning of the driven unit to the plunger assembly: the driven unit are spur gear, the reduction gearbox and electric motor,
- mount the handle (locking device) through the supporting plate 4 to the platen, and
- install the mould to supporting plate 3 and the platen.

3.2. Working drawing

The working drawings were produced based on the earlier designed that state all components of the machine. It gives further internal and external details of the entire machine with specifications for the construction. The construction was purely based on the designed made. The constructed machine is shown in Figs. 2 to 7.

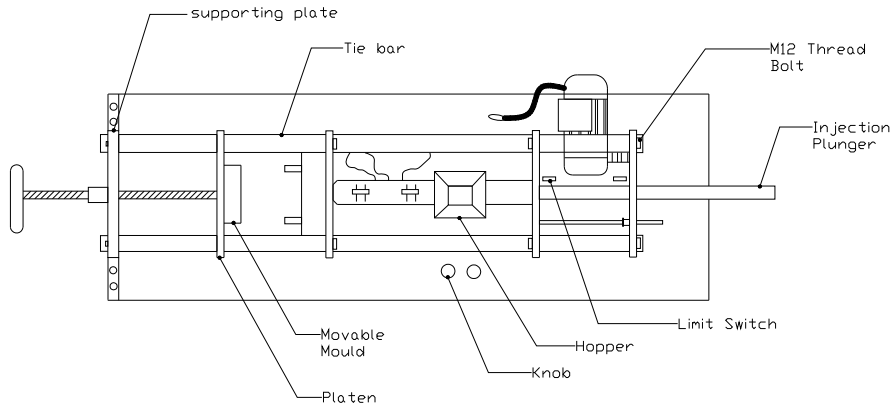

Fig. 2. Plan View of the Constructed Injection Moulding Machine.

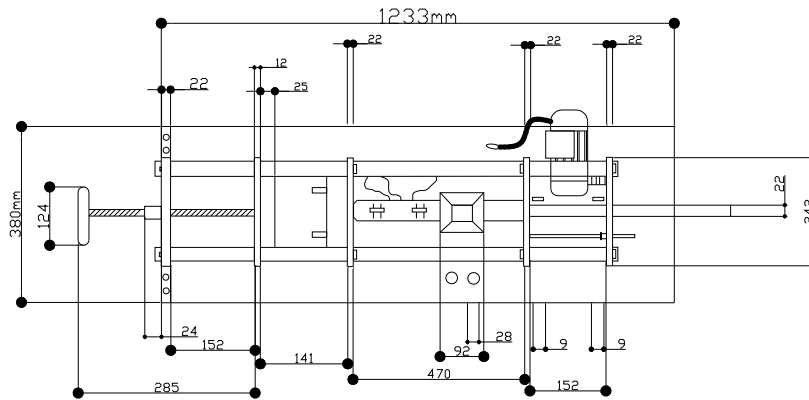

Fig. 3. Dimensional Plan View of the Constructed Injection Moulding Machine.

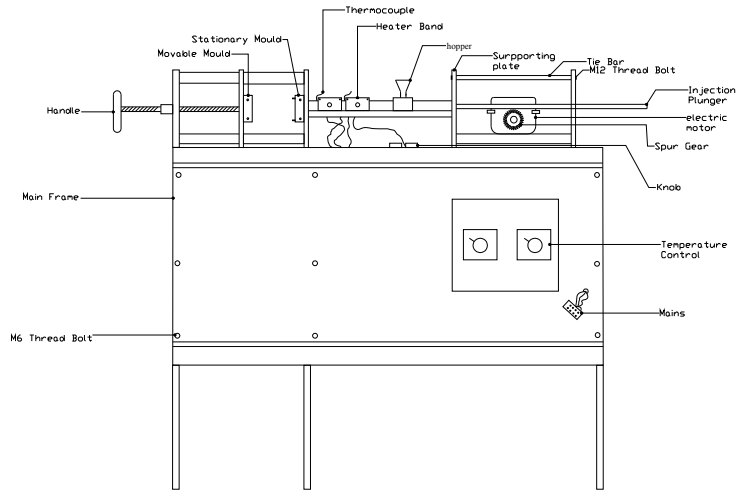

Fig. 4. Front View of the Constructed Injection Moulding Machine.

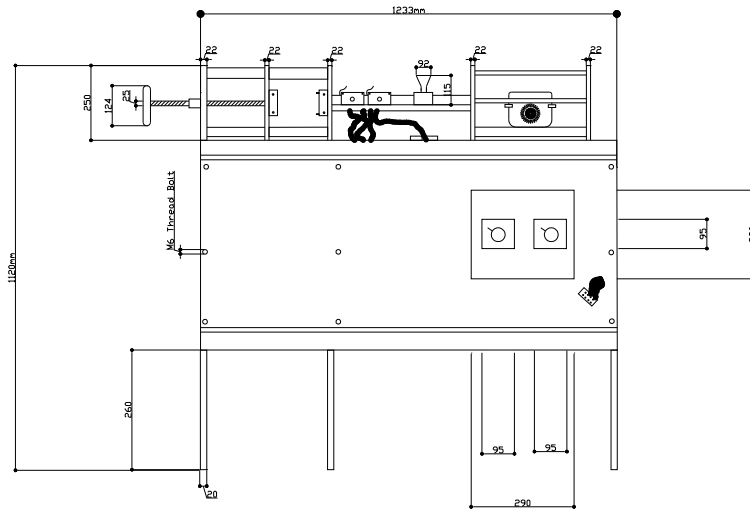

Fig. 5. Dimensional Front View of the Constructed Injection Moulding Machine.

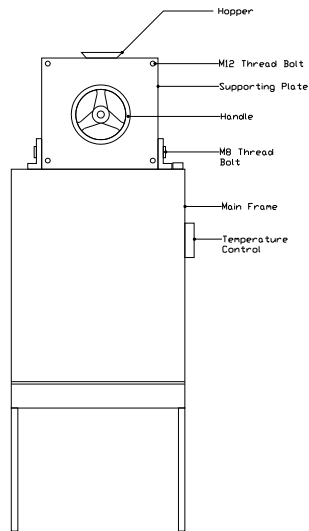

Fig. 6. Side View of the Constructed Injection Moulding Machine.

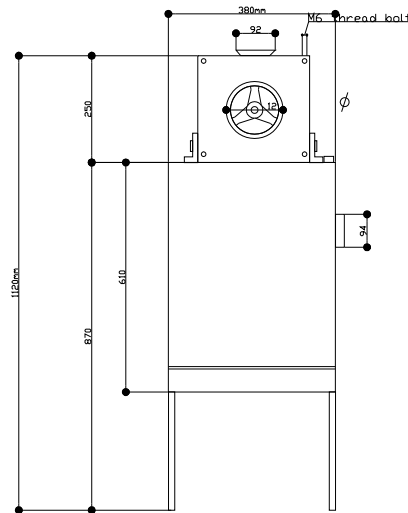

Fig. 7. Dimensional Side View of the Constructed Injection Moulding Machine.

Constructional techniques

The major techniques employed in construction of the designed machine include machining operation on lathe machine, drilling operations on drilling machine, flame cutting using oxyacetylene gas welding machines, grinding for good finishing, electric welding using arc welding machine. Basically, these constructional techniques were broken down into four sub-heading namely; cutting operation, machining operation, welding operation and assembly; and finishing operation.

3.3. Materials selection

Materials are selected based on designed and metallurgical properties of the materials such as machinability, formability, weldability that greatly influence the construction methods and other joining methods. Other factors considered are cost of the materials; and mechanical properties of the materials.

- **Materials**

The following materials used in the construction of this machine are medium carbon steel used for injection plunger, barrel and nozzle. Mild steel was used for hopper, supporting plates, tie bars, platen, mould, bolts, and main frame. Other materials used are thermocouples, limit switches, knobs (control button), bolts, and 4-core flexible wires, heat resistance wires, and contactors, red and light green paints.

- **Specification of Materials Selection**

The following parts and materials were used to achieve the set objectives. They are summarized and presented in Table 1.

Table 1. Specifications for Materials Utilized.

	Parts	Materials used	Size (mm)	Qty	Production
1	Injection plunger	Medium carbon steel	$\phi 22 \text{ mm} \times 900 \text{ mm}$	1	Fabrication
2	Barrel	Medium carbon steel	$\phi 45 \text{ mm} \times 470 \text{ mm}$	1	Fabrication
3	Hopper	Mild steel	$92 \text{ mm} \times 92 \text{ mm} \times 115 \text{ mm}$	1	Fabrication
4	Supporting plates	Mild steel	$242 \text{ mm} \times 22 \text{ mm} \times 250 \text{ mm}$	4	Brought out
5	Tie bars	Mild steel	<u>Plate 1 to 2</u> $\phi 25 \text{ mm} \times 305 \text{ mm}$, <u>Plate 2 to 3</u> $\phi 25 \text{ mm} \times 470 \text{ mm}$, <u>Plate 3 to 4</u> $\phi 25 \text{ mm} \times 152 \text{ mm}$	4	Brought out
6	Platen	Mild steel	$240 \text{ mm} \times 12 \text{ mm} \times 240 \text{ mm}$	1	Brought out
7	Mould	Mild steel	$122 \text{ mm} \times 25 \text{ mm} \times 122 \text{ mm}$	1	Fabrication
8	Bolts	Mild steel	M6 thread, M8 thread, M12 thread.	18 6 20	Brought out
9	Main frame	Mild steel	$1233 \text{ mm} \times 380 \text{ mm} \times 870 \text{ mm}$	1	Brought out
10	Handle	Mild steel	$\phi 124 \text{ mm} \times 260 \text{ mm}$	1	Fabrication
11	Electric motor		G-80 type	1	Brought out
12	Contactors		10 amps	4	Brought out
13	Temperature controls		J-type	2	Brought out
14	Thermocouples		J-type	2	Brought out
15	Limit switches		T85	2	Brought out
16	Knobs (control button)		$\phi 28 \text{ mm}$	2	Brought out
17	Nozzle	Medium carbon steel		1	Fabrication

3.4. Equipment

The equipment used are as follows: electric motor, other such as mainframe is cut into sizes using oxyacetylene gas welding, facing operation mould, barrel, injection plunger, and handle were faced using the lathe machine., drilling operation, milling operation, and tapping operation using drilling machine, milling machine and tapping machine respectively. Components such as the drilling operation on the lathe machine were performed on the components such as the mould, barrel, tie bars, and the supporting plates. Milling operation was carried out on the barrel, and the spur gear teeth. Tapping operation was also carried out on the tie bars.

All the general finishing operation was carried out on the machine such as grinding of all rough edges using a hand grinding machine. Cutting saw or frame cutting were used for cutting the various metals into sizes and required shapes. Metals such as the supporting plates, platen, tie bars, barrel, injection plunger, and hopper were cut sizes using manual hacksaw.

3.5. Operation procedure

The operational principles of this machine are as follows: switch on the heater for one hour, and set the electric controllers to the desired temperature, and fill the hopper with materials (high-density polyethylene and master batch). When beginning to inject the molten resins to the mould, make sure the mould is close and there are two limit switches that determine the stroke of forward and backward movement of the injection plunger [4]. That is, when the injection plunger reaches the maximum forward stroke predetermined for the particular mould, a limit switch will be actuated and this will stop the electric motor movement. The same way goes to the backward stroke and this determined the amount of molten resins that goes into the mould. If the mould functions properly, the finished product will fall out of the mould on its own.

3.6. Testing

In testing the constructed machine, the materials used for the test are high density polyethylene and master batch. The reasons are due to excellent chemical resistance, very tough at low temperatures; and easy of processing.

The steps taken during the test are as follows: materials (resins) are fed into the hopper, the heater bands heat up the barrel for an hour and when it reaches a high temperature (220°C), and the resins melt into liquid. Thereafter, the mould is held closed by a handle, which serves as a locking device and a knob is pressed and the injection plunger forces the molten resins under pressure through the sprue into the closed mould cavity, where it cools into a required shape.

The volume of the plastic shot is controlled by a limit switch, which shuts off the electric motor and the plunger when it has reached its stroke. During solidification, a knob is pressed for the injection plunger to move backward until enough molten resins are being accumulated for the next shot, and the mould is then opened, and the required product will fall out of the mould on its own.

4. Results and Discussions

It was found that the major problems in the moulding process are:

- a) The problem of product or molding that was not fully injected; and this was due to the melt temperature either too low or injection has been started before the necessary temperature has been reached. It may also be due to either the sprue channel is too weak, and or difficulty in the air escaped from mould [5].
- b) The problem of sinks or blisters on the product or molding was due to the melt temperature too high, the sprue channel too weak or unsuitably located, and the mould is insufficiently cooled.
- c) Also, the problem of product discolors observed may be due to the overheated of the melt and the colour fastness of the material.

5. Conclusions

The design, construction and testing of the small injection molding machine had been successfully accomplished. It was observed and concluded that the

practicability and efficiency of the machine depends on strict compliance with the operational procedures of the machine.

This work was designed and constructed for the small-scale production of small plastic articles. Hence, it can be recommended for small-scale investors that are willing to produce small plastic articles such as key holders, clothes pegs, flat rulers, bottle covers/caps and tally.

References

1. Kwong, C.K.; and Smith, G.F. (1998). A computational system for process design of injection moulding: Combining blackboard-based expert system and case-based reasoning approach. *International Journal of Advanced Manufacturing Technology*, 14(4), 239-246.
2. Niebel, B.W.; Draper, A.B.; and Wysk, R.A. (1989). *Modern manufacturing process engineering*. McGraw-Hill Book Company, Singapore, 435-437.
3. Lindberg, R. A. (1990). *Processes and materials of manufacture*. Prentice-Hall of USA, Inc., New Jersey, 247-250.
4. Netstal, C. (1978). Instruction manual for injection moulding machine. *Netsal Machine and Foundry Limited*, Switzerland, 36-60.
5. Simonson, J.R. (1997). *Engineering heat transfer*. Mc-Graw-Hill Book Company, New York, USA, 352.
6. Khurmi, R.S.; and Gupta, J.K. (2003). *Machine design*. S. Chand and Company Limited, New Delhi, India, 920-959.
7. Hughes, E. (1995). *Electrical technology*. Pearson Education Limited. Harlow, England, 699-713.
8. Joseph, E.S.; and Mischke, C.R. (1976). *Mechanical engineering design*. McGraw-Hill Publishers, Aucland, 162-164.

Appendix A

Design Calculations

a) Diameter of injection plunger

In the injection plunger design, the plunger diameter is calculated from Eq. (8),

$$d = \sqrt{\frac{4m}{\pi\rho l}} \quad (8)$$

where

melt mass, $m = 2.7$ kg (laboratory measurement),

melt density of resin, $\rho = 7900$ kg/m³,

length of the plunger, $l = 0.9$ m.

Substituting these values into Eq. (8) gives

$$d = \sqrt{\frac{4 \times 2.7}{\pi \times 7900 \times 0.9}} = 0.022 \text{ m}$$

This implies that $d = 22 \text{ mm}$

b) Number of teeth required on the plunger rack

The number of teeth required is determined from Eq. (9)

$$\text{Number of teeth required on the plunger rack} = \frac{\text{length of travel expected of plunger}}{\text{circular pitch distance}} \quad (9)$$

where

Length of travel expected of plunger = $180 \text{ mm} \left(\frac{\text{length of plunger}}{5} \right)$ and circular pitch distance = 6 mm/tooth

Therefore, substituting these values into Eq. (9) gives

$$\text{Number of teeth required on the plunger rack} = \frac{180 \text{ mm}}{6 \text{ mm/tooth}} = 30 \text{ Teeth}$$

c) Number of teeth required on spur gear (pinion)

The number of teeth required on the spur gear is determined from Eq. (10),

$$\text{Number of teeth required on spur gear} = \frac{\pi \times \text{diameter of pitch circle}}{\text{circular pitch distance}} \quad (10)$$

where

Diameter of pitch circle = 76 mm and

Circular pitch distance = 6 mm/tooth

Substitution of these values into Eq. (10) gives

$$\text{Number of teeth required on spur gear} = \frac{\pi \times 76 \text{ mm}}{6 \text{ mm/tooth}} = 40 \text{ Teeth}$$

d) Motor selection

In the selection of the electric motor, the following parameters are required:

The angular velocity (ω) is calculated from Eq. (11),

$$\omega = \frac{v}{r} \quad (11)$$

where,

Injection linear velocity, $v = 1.61 \text{ m/s}$ [6]

Radius of motor shaft, $r_s = 12 \text{ mm} = 0.012 \text{ m}$

Substitute these values into Eq. (11) to have

$$\omega = \frac{1.61}{0.012} = 134 \text{ rad/s}$$

Most electric motors operate between 500 rpm and 3000 rpm in accordance with Hughes [7]. Hence, the number of revolution (N) is determined using Eq. (12),

$$N = \frac{60\omega}{2\pi} \quad (12)$$

where angular velocity $\omega = 134 \text{ rad/s}$ and the substitution into Eq. (12) gives

$$N = \frac{60 \times 134}{2\pi} = 1279.5 \text{ rpm}$$

This implies that,

$$N = 1280 \text{ rpm}$$

In addition, the torque (T) of the motor is calculated from Eq. (13),

$$T = Fr_s \quad (13)$$

where

the turning force of G.80 type electric motor shaft, $F = 0.112 \text{ N}$ and

the radius of the motor shaft, $r_s = 0.012 \text{ m}$ [7], therefore,

$$T = 0.112 \times 0.012 = 0.00134 \text{ Nm}$$

Likewise, the power (P) is determined from Eq. (14)

$$P = T\omega \quad (14)$$

Recall that the torque, $T = 0.00134 \text{ Nm}$ and angular velocity, $\omega = 134 \text{ rad/s}$, therefore,

$$P = 0.00134 \times 134 = 0.17956 \text{ kW. This implies that,}$$

$$P = 0.18 \text{ kW}$$

e) Leverage on the handle

In the design of the handle, the leverage on the handle (M_L) of the machine is calculated from Eq. (15) [8]

$$M_L = m_h g d_1 \quad (15)$$

where,

mass of platen, $m_h = 5.39 \text{ kg}$ (Laboratory measurement),

acceleration due to gravity, $g = 9.81 \text{ m/s}^2$, and

distance in which the handle, d_1 moves the platen = 180 mm (one fifth of the length of the plunger) = 0.18 m.

Substituting these values into Eq. (15) gives

$$M_L = 5.39 \times 9.81 \times 0.18 = 9.52 \text{ J}$$