

EVALUATING A NEW SUBCARRIER MAPPING ICI-SC SCHEME USING LINEAR MAXIMUM LIKELIHOOD ALAMOUTI COMBINER (LMLAC) DECODING TECHNIQUE

AZLINA IDRIS^{1,2,*}, KAHARUDIN DIMYATI³, SHARIFAH K. SYED YUSOF⁴

¹Faculty of Electrical Engineering, Universiti Teknologi MARA, Malaysia

²Department of Electrical Engineering, Universiti Malaya, Malaysia

³Faculty of Engineering, National Defence University of Malaysia, Malaysia

⁴Faculty of Electrical Engineering, Universiti Teknologi Malaysia

*Corresponding Author: azlina_idr@yahoo.com

Abstract

This paper presents a new subcarrier mapping scheme ICI-SC technique that use Linear Maximum Likelihood Alamouti Combiner (LMLAC) as a decoding technique to mitigate intercarrier interference (ICI) problem with low complexity decoding system for space time frequency block codes (STFBC) orthogonal frequency division multiplexing (OFDM) in the frequency selective environments. We provide details of the mathematical models of the proposed scheme and simulate its error performance caused by frequency offset (FO). We also analyze the impact of the STFBC of the system. The simulation results showed that the scheme has the ability to reduce ICI effectively with a low decoding complexity and maximum diversity in terms of bandwidth efficiency and also in the bit error rate (BER) performance especially at high signal to noise ratio.

Keywords: Intercarrier interference self cancellation, Space time frequency block code, Linear maximum likelihood Alamouti combiner, Signal to noise ratio, Frequency offset.

1. Introduction

Orthogonal frequency division multiplexing OFDM is an effective technique to mitigate inter-symbol interference that multipath delay may cause in a frequency selective environment [1, 2]. This phenomenon brings about a frequency of selective fading due to the different echoes of transmitted symbols overlapping at the receiving end. This factor can lead to the BER degradation [3, 4]. To effectively

Nomenclatures

E_b/N_o	Signal to noise ratio
$H_{m,n}(k)$	Channel coefficient
K	Number of subcarriers
L	Path gain
M	Transmit antennas
N	Receive antennas
R	Repeated data
S_1	Transmit symbol 1 using maximum likelihood
\hat{S}_1	Transmit symbol 1 using linear combiner
S_2	Transmit symbol 2 using maximum likelihood
\hat{S}_2	Transmit symbol 2 using linear combiner
X_m	Codeword
$Y_1(k)$	Received signal Y_1 at time k using linear combiner
$\bar{Y}_1(k)$	Received signal Y_1 at frequency k using linear combiner
$Y_1(k+1)$	Received signal Y_1 at time $k+1$ using linear combiner
$\bar{Y}_1(k+1)$	Received signal Y_1 at frequency $k+1$ using linear combiner
$Y_2(k)$	Received signal Y_2 at time k using linear combiner
$\bar{Y}_2(k)$	Received signal Y_2 at frequency k using linear combiner
$Y_2(k+1)$	Received signal Y_2 at time $k+1$ using linear combiner
$\bar{Y}_2(k+1)$	Received signal Y_2 at frequency $k+1$ using linear combiner
$Y_f(k)$	Received signal at frequency k
$Y_f(k+1)$	Received signal at frequency $k+1$
$Y_T(k)$	Received signal at time k
$Y_T(k+1)$	Received signal at time $k+1$

Greek Symbols

α_{ij}	Complex gain
ρ_{ij}	Normalized interference coefficient transmit symbols
σ_H^2	Average power of the channel gain
σ_S^2	Average energy of the transmit symbols
σ_w^2	Average noise
ξ	Average signal to noise ratio

Abbreviations

BER	Bit error rate
FO	Frequency offset
ICI	Intercarrier interference
ICI-SC	Intercarrier interference self cancellation
LMLAC	Linear maximum likelihood Alamouti combiner
MIMO	Multiple-input and multiple-output
ML	Maximum likelihood
OFDM	Orthogonal frequency division multiplexing
STFBC	Space time frequency block codes

mitigate the impairments of a multipath fading channel, yet still maintaining high-data rates in a limited bandwidth, the OFDM can be used [5, 6]. Multiple antennas can be combined with OFDM to increase diversity gain and to improve spectral efficiency through spatial multiplexing [7, 8].

It is also evident that the combination of MIMO and OFDM produces a powerful technique for providing high data rates over frequency-selective fading channels. It is now a leading application for future fourth generation (4G) wireless communication systems [9, 10].

This paper addresses two related problems in realizing practical mobile communication system with MIMO and OFDM technologies. First and foremost, it is concerned about ICI in the system. In the case of SISO OFDM, the authors in [11-13] proposed ICI-SC coding or polynomial cancellation coding to mitigate ICI caused by FO effectively. However, this scheme inherently reduces throughput and bandwidth efficiency by a factor of 2 (repeated symbols) [13]. Nevertheless, this problem can be improved or compensated by using the higher order modulation scheme with a high transmission rate [14, 15].

OFDM has become more complex and time consuming in MIMO system utilizing maximum likelihood (ML) decoding, mainly due to the large size of the system constellation and the codeword structure and it become the second problems addressed in this paper. To overcome these problems, the LMLAC decoding techniques can be introduced as they can provide a satisfactory decoding performance in most cases and a simple method [16].

This paper is organized as follows: In Section 2, a simulation model of STFBC in OFDM system with FO using a new subcarrier mapping scheme ICI-SC technique will be derived and discussed. We have derived a different LMLAC decoding algorithm and briefly described the derivation of proposed equation in MIMO-OFDM system in Section 3. In Section 4, simulation results will be analyzed in terms of BER and E_b/N_o performance. Finally, some concluding remarks were given in Section 5.

2. System Model

As illustrated in Fig. 1, we focused on MIMO-OFDM system with $M=2$ Transmit and $N=2$ Receive antennas. Let the number of subcarriers in the OFDM modulators as K . Using typical urban (TU) channel, the L -path quasi static Rayleigh fading channel model between each pair of transmit and receive antennas used in this system is six paths COST207.

In the case of MIMO-OFDM, the repetition is done with $r=2$ where r is how many times the data is repeated. The interference cancellation modulation (ICM) is then applied to STFBC using the repeating scheme but the repeated symbols are signed-reversed to form a new data conversion subcarrier mapping scheme ICI-SC technique codeword as follows:

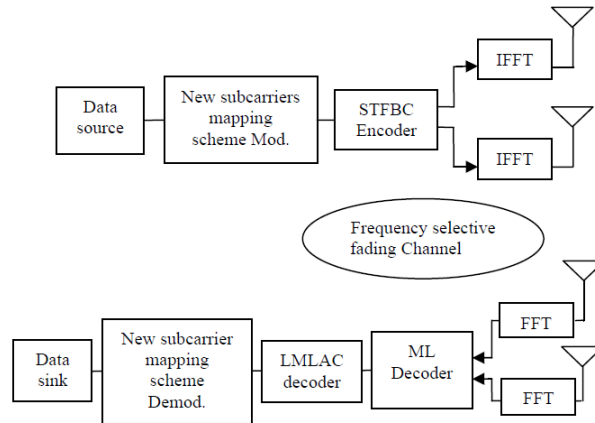

Fig. 1. Block Diagram for STFBC with New Subcarrier Mapping Scheme ICI-SC Technique using a MIMO-OFDM System.

$$X_m = \begin{bmatrix} X_1(0) & \dots & X_2(0) & \dots & X_M(0) \\ -X_1(\frac{N}{2}-1) & \dots & -X_2(\frac{N}{2}-1) & \dots & -X_M(\frac{N}{2}-1) \\ \vdots & & \vdots & & \vdots \\ X_1(\frac{N}{2}-1) & \dots & X_2(\frac{N}{2}-1) & \dots & X_M(\frac{N}{2}-1) \\ -X_1(\frac{N}{2}-1) & \dots & -X_2(\frac{N}{2}-1) & \dots & -X_M(\frac{N}{2}-1) \\ X_1(\frac{N}{2}) & \dots & X_2(\frac{N}{2}) & \dots & X_M(\frac{N}{2}) \\ -X_1((N-1)+\frac{N}{2}) & \dots & -X_2((N-1)+\frac{N}{2}) & \dots & -X_M((N-1)+\frac{N}{2}) \\ \vdots & & \vdots & & \vdots \\ X_1(N-1) & \dots & X_2(N-1) & \dots & X_M(N-1) \\ -X_1((N-1)+\frac{N}{2}) & \dots & -X_2((N-1)+\frac{N}{2}) & \dots & -X_M((N-1)+\frac{N}{2}) \end{bmatrix} \quad (1)$$

Applying the conjugate interference cancellation modulation (ICM) scheme to the repeating signal to reduce ICI, the codeword becomes:-

$$X_m = \begin{bmatrix} X_1(0) & \dots & X_2(0) & \dots & X_M(0) \\ -X_1(\frac{N}{2}-1)^* & \dots & -X_2(\frac{N}{2}-1)^* & \dots & -X_M(\frac{N}{2}-1)^* \\ \vdots & & \vdots & & \vdots \\ X_1(\frac{N}{2}-1) & \dots & X_2(\frac{N}{2}-1) & \dots & X_M(\frac{N}{2}-1) \\ -X_1(\frac{N}{2}-1)^* & \dots & -X_2(\frac{N}{2}-1)^* & \dots & -X_M(\frac{N}{2}-1)^* \\ X_1(\frac{N}{2}) & \dots & X_2(\frac{N}{2}) & \dots & X_M(\frac{N}{2}) \\ -X_1((N-1)+\frac{N}{2})^* & \dots & -X_2((N-1)+\frac{N}{2})^* & \dots & -X_M((N-1)+\frac{N}{2})^* \\ \vdots & & \vdots & & \vdots \\ X_1(N-1) & \dots & X_2(N-1) & \dots & X_M(N-1) \\ -X_1((N-1)+\frac{N}{2})^* & \dots & -X_2((N-1)+\frac{N}{2})^* & \dots & -X_M((N-1)+\frac{N}{2})^* \end{bmatrix} \quad (2)$$

By allocating a pair of complex signals, the phase different between two adjacent subcarriers varies with respect to the signal itself [17]. This method is called new data conjugate subcarrier mapping scheme ICI-SC technique.

3. Linear Maximum Likelihood Decoding of STFBC

Three LMLAC decoding techniques are considered, namely the conventional combiner, maximum diversity combiner and orthogonal combiner. Different LMLAC decoding techniques have different pairs to combine the received signals and the average E_b/N_o with combination space time and space frequency is also different.

3.1. Conventional combiner

In conventional ML decoder, the received signals at times (T) and frequencies (F) k and $k+1$ for STFBC can be written as follows:-

$$Y_T(k) = H_{1,1}(1)S_1 + H_{1,2}(1)S_2 \quad (3)$$

$$Y_T(k+1) = H_{2,1}(2)S_1 - H_{2,2}(2)S_2 \quad (4)$$

$$Y_F(k) = H_{1,1}(1)S_1 + H_{2,1}(1)S_2 \quad (5)$$

$$Y_F(k+1) = H_{2,2}(1)S_1 - H_{1,2}(1)S_2 \quad (6)$$

by which the transmit symbol using maximum likelihood equations, S_1 and S_2 are given as

$$S_1 = (X_1(k)[H_{1,1}(k)S(0) + H_{2,1}(k)^* S(0)^*] - X_2(k)^*[H_{1,2}(k)S(1) + H_{2,2}(k)^* S(-1)^*] \\ + (1/4 \sum_{l=0}^{N-1} X_1(l)H_{1,1}(k)S(l-k) + X_2(l)^* H_{2,2}(l)^* S(l-k-1)) + N_k) \quad (7)$$

$$S_2 = (X_2(k)[H_{2,1}(k)S(0) - H_{1,2}(k)^* S(0)^*] + X_1(k)^*[H_{2,2}(k)S(1) + H_{1,1}(k)^* S(-1)^*] \\ + (1/4 \sum_{l=0}^{N-1} X_2(l)H_{2,1}(k)S(l-k) - X_1(l)^* H_{1,2}(l)^* S(l-k-1)) + (N_k + 1)) \quad (8)$$

The channel coefficient is $H_{m,n}(k)$ whereas the value of m , n and k are indexes of transmitting antennas, subcarriers and time. Then, the pairs $(H_{1,1}^*(1), H_{2,1}(1))$, $(H_{2,1}^*(1), -H_{1,1}(1))$ and $(H_{1,1}^*(2), H_{2,1}(2))$, $(H_{2,1}^*(2), -H_{1,1}(2))$ that are used to combine the received signals Y_1 and Y_2 at k and $k+1$ for time domain become:

$$Y_1(k) = H_{1,1}(1)^* Y_T(k) + H_{2,1}(1) Y_T(k+1)^* \quad (9)$$

$$Y_2(k) = H_{1,1}(2)^* Y_T(k) + H_{2,1}(2) Y_T(k+1)^* \quad (10)$$

$$Y_1(k+1) = H_{2,1}(1)^* Y_T(k) - H_{1,1}(1) Y_T(k+1)^* \quad (11)$$

$$Y_2(k+1) = H_{2,1}(2)^* Y_T(k) - H_{1,1}(2) Y_T(k+1)^* \quad (12)$$

Consequently, the frequency domain that are being used to combine the received signal are; $(H_{1,2}^*(1), H_{2,2}(1))$, $(H_{2,1}^*(1), -H_{1,2}(1))$ for the received signals Y_1 and $(H_{1,1}^*(2), H_{2,1}(2))$, $(H_{2,1}^*(2), -H_{1,1}(2))$ for the received signals Y_2 . The received signal for frequency domain becomes:

$$\bar{Y}_1(k) = H_{1,2}(1)^* Y_F(k) + H_{2,2}(1) Y_F(k+1)^* \quad (13)$$

$$\bar{Y}_2(k) = H_{1,1}(2)^* Y_F(k) + H_{2,1}(2) Y_F(k+1)^* \quad (14)$$

$$\bar{Y}_1(k+1) = H_{2,2}(1)^* Y_F(k) - H_{1,2}(1) Y_F(k+1)^* \quad (15)$$

$$\bar{Y}_2(k+1) = H_{2,1}(2)^* Y_F(k) - H_{1,1}(2) Y_F(k+1)^* \quad (16)$$

Substituting Eqs. (9), (10), (13) and (14) into Eq. (17), then the transmit symbols resulted using conventional combiner is:-

$$\hat{S}_1 = Y_1(k) + Y_2(k) + \bar{Y}_1(k) + \bar{Y}_2(k) \quad (17)$$

and substituting Eqs. (11), (12), (15) and (16) into Eq. (18)

$$\hat{S}_2 = Y_1(k+1) + Y_2(k+1) + \bar{Y}_1(k+1) + \bar{Y}_2(k+1) \quad (18)$$

By referring to [16], the equation of average E_b/N_o via the combination of space time and space frequency it becomes:

$$\xi = \frac{(1 + \alpha_{ij}) \sigma_H^2 \sigma_s^2}{2\sigma_w^2 + (\rho_{ij}) \Gamma\left(\frac{3}{2}\right) \sigma_H^2 \sigma_s^2} \quad (19)$$

by which σ_s^2 is the average energy of the transmit symbols, σ_H^2 is the average power of the channel gain, σ_w^2 is the average noise, α_{ij} is the complex gain at the value of i (time) and j (frequency), and ρ_{ij} is the normalized interference coefficient transmit symbols at i and j .

3.2. Maximum diversity combiner

We now propose a second technique to achieve performance of low complexity, with maximum diversity order. By using the same mapping method, the received signal for time domain pair are $(H_{1,2}^*(1), H_{2,2}(2))$, $(H_{2,2}^*(2), -H_{1,2}(2))$ and $(H_{1,1}^*(1), H_{2,1}(2))$, $(H_{2,1}^*(1), -H_{1,1}(2))$, and for frequency domain pair are $(H_{1,1}^*(1), H_{2,2}(1))$, $(H_{2,1}^*(1), -H_{1,2}(1))$ and $(H_{1,1}^*(2), H_{2,2}(2))$, $(H_{2,1}^*(2), -H_{1,2}(2))$.

By employing the same method as in Eqs. (17) and (18) on different pairs, we obtained the equations \hat{S}_1 and \hat{S}_2 . From [16], the resulting average E_b/N_o for space time and space frequency is:

$$\xi = \frac{2\sigma_H^2 \sigma_s^2}{2\sigma_w^2 + (\rho_{ij}) \sigma_H^2 \sigma_s^2} \quad (20)$$

3.3. Orthogonal combiner

Next, we propose another technique known as orthogonal combiner. Let's substitute Eqs. (9) to (16) into the equations for \hat{S}_1 and \hat{S}_2 , then, combine different pairs in the time domain $Y_1 = (H_{1,1}^*(2), H_{2,1}(1))$, $(H_{2,1}^*(2), -H_{1,1}(1))$ and

$Y_2 = (H_{1,2}^*(2), H_{2,2}(1))$, $(H_{2,2}^*(2), -H_{1,2}(1))$ and apply the frequency domain $Y_1 = (H_{1,2}^*(1), H_{1,1}(1))$, $(H_{2,2}^*(1), -H_{1,1}(1))$ and $Y_2 = (H_{1,2}^*(2), H_{2,1}(2))$, $(H_{2,2}^*(2), -H_{1,1}(2))$.

From the above pairs, the received signals for orthogonal combiner can obtain \hat{S}_1 and \hat{S}_2 respectively. The average E_b/N_o with the combination of space time and space frequency is as obtained below [16]:

$$\xi = \frac{2(\alpha_{ij})\sigma_H^2\sigma_S^2}{2\sigma_w^2} \quad (21)$$

At this stage, we can conclude that, in STFBC MIMO-OFDM, as the average E_b/N_o becomes higher, the noise in system become lower.

4. Simulation Results and Discussion

This section shows the simulation of the proposed STFBC design methods with the insertion of LMLAC Decoding. For this system, we use the six-path COST 207 (Jakes model) typical urban (TU) channel model [18] over a more realistic model. By using OFDM base, the simulation parameters are shown in Table 1.

Table 1. Simulation Parameters for the System [19].

Parameters	Value
Bandwidth (BW)	1.25MHz
Sampling frequency	1.92MHz
Sampling time	5.208×10^{-7} second
No. of subcarriers	76 subcarriers
Modulation technique	64-QAM
Maximum Doppler frequency	120Hz
IFFT size	128
Channel model	COST207 Typical Urban (TU) channel Path delays, $L_p = (0, 0.2 \times 10^{-6}, 0.5 \times 10^{-6}, 1.6 \times 10^{-6}, 2.3 \times 10^{-6}, 5.0 \times 10^{-6})$ seconds Average path gains = [0.5011, 1.122, 0.6309, 0.251, 0.158, 0.1] dB

The simulation results presented BER curves as functions of E_b/N_o as shown in Fig. 2. Figure 2, depicts the BER performance of STFBC with new data conjugate and data conversion subcarrier mapping scheme ICI-SC technique by using four types of subcarrier mapping compared at NFO=5%. BER for data conjugate improves at high E_b/N_o than conversion method for all decoding methods using new subcarrier mapping scheme. The data conjugate with maximum diversity combiner has the best BER performance compared to the other three decoding techniques because the system has a low decoding complexity system with optimal distance that can achieve maximum frequency diversity and less interference. For instance, at $\text{BER} = 2 \times 10^{-2}$, the E_b/N_o value for maximum diversity combiner with data conjugate is 4.4 dB. The performance loss of data conjugate between maximum diversity combiner with conventional combiner, orthogonal combiner and ML decoding are about 2.1 dB, 4

dB and 4.5 dB respectively. It is noticeable that the ML decoding performed worse than other techniques in linear combiner and performs the lowest value of E_b/N_o . It is also shown that maximum diversity combined with new data conjugate subcarrier mapping scheme ICI-SC technique from Eq. (2) yields the best performance with low complexity and less time consumption compared with other linear combiner techniques, and produces the highest E_b/N_o values from Eq. (20). In overall, linear combiner performs at better BER performance with higher E_b/N_o from Eqs. (19), (20) and (21) than the ML decoding with a NFO=5%.

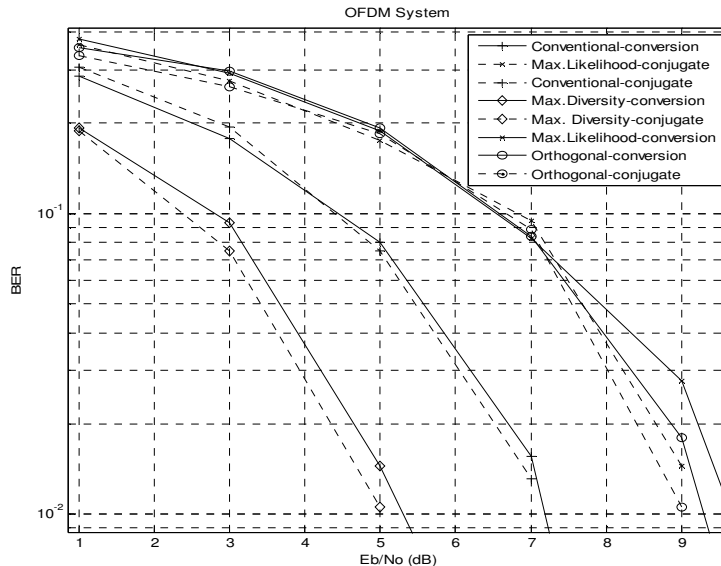

Fig. 2. STFBC Systems for $f_o = 0.05$ with New Data Conjugate and Data Conversion Subcarrier Mapping Scheme ICI-SC Technique Using Different Decoding Techniques.

Figure 3 depicts the simulation results of BER performance of STFBC with new data conjugate subcarrier mapping schemes ICI-SC technique with NFO = (0%, 5%, 15%, 20%) using maximum diversity combiner decoding technique. Figure 3 shows that when the NFO is 0% at $BER=3 \times 10^{-2}$, the performance loss is about 0.9 dB for NFO=5%, 2.2 dB for NFO=15% and 6 dB for NFO=20% respectively. The value of E_b/N_o needs to be compensated for the effect of FO increases. The new data conjugate subcarrier mapping scheme from Eq. (2) at NFO=0% produces the best BER performance for all NFO in the system. It is proven that there is a significant improvement when the value of FO decreases in the system. The above simulation shows that the lower the FO the better performance of the system, which can increase the E_b/N_o and decrease the BER. If the FO decreases, the shift of BER curves with higher diversity order is larger than the shift of BER curves with lower diversity order. Therefore, the higher diversity order systems are more robust to the effect of FO. From the above simulation, the result confirm that the BER performance for a new subcarrier mapping scheme ICI-SC technique using maximum diversity combiner method produces ICI reduction in the system with low complexity decoding technique and can achieve maximum diversity order.

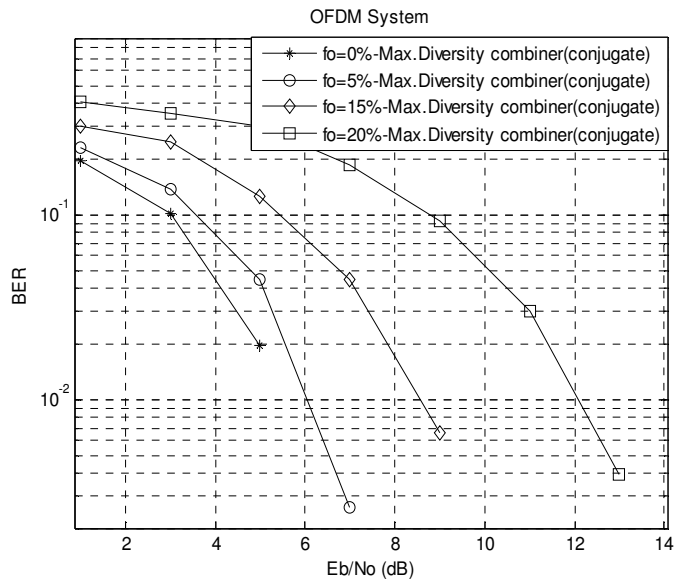

Fig. 3. STFBC Systems for Different f_o with New Data Conjugate Subcarrier Mapping Scheme ICI-SC Technique Using Maximum Diversity Combiner Decoding Techniques.

5. Conclusions

In this paper, a new subcarrier mapping technique that is combined with LMLAC decoding techniques is proposed using STFBC MIMO-OFDM system. The simulation results have shown that the performance improvement of BER can achieve the objectives of this paper to study for ICI reduction methods with low decoder complexity and maximum diversity order system. These has proven that the proposed subcarrier mapping ICI-SC technique combined with maximum diversity combiner technique using STFBC can be considered as a promising candidate in the MIMO OFDM-based system.

References

1. Falconer, D.; Ariyavisitakul, S.L.; Benyamin-Seeyar, A.; and Eidson, B. (2002). Frequency domain equalization for single-carrier broadband wireless systems. *IEEE Communication Magazine*, 40(4), 58-66.
2. Omar, M.H.; Hassan, S.; and Shabli, A.H.M. (2009). COGRADNET: Ubiquitous heterogeneous wireless networks. *Journal of Engineering Science & Technology (JESTEC)*, 4(2), 184-195.
3. Weifeng, S.; Safar, Z.; and Liu K.J.R. (2005). Towards maximum achievable diversity in space, time, and frequency: Performance analysis and code design. *IEEE Transactions on Wireless Communications*, 4(4), 1847-1857.
4. Prianka, F.; Matin, M.A.; Saleh, A.Z.; and Ali, M.A.M. (2010). BER analysis of OFDM with improved ICI self-cancellation scheme. *International Conference on Material and Manufacturing Technology (ICMMT)*.

5. Weifeng, S.; Safar, Z.; Olfat, M., and Liu, K.J.R. (2003). Obtaining full-diversity space-frequency codes from space-time codes via mapping. *IEEE Transactions on Signal Processing*, 51(11), 2905-2916.
6. Hwang, T.; Yang, C.; Wu, G.; Li, S.; and Ye Li, G. (2009). OFDM and its wireless applications: A survey. *IEEE Transactions on Vehicular Technology*, 58(4), 1673-1649.
7. Stuber, G.L.; Barry, J.R.; Mclaughlin, S.W.; Li, Y.; Ingram, M.A.; and Pratt, T.G. (2004). Broadband MIMO-OFDM wireless communications. *Proceedings of the IEEE*, 92(2), 271-294.
8. Hwang, T.; Yang, C.; Wu, G.; Li, S.; and Ye Li, G. (2009). OFDM and its wireless applications: A survey. *IEEE Transactions on Vehicular Technology*, 58(4), 1673-1649.
9. Russel, M.; and Stuber, G.L. (1995). Interchannel interference analysis of OFDM in a mobile environment. *IEEE 45th Vehicular Technology Conference*, 2, 820-824.
10. Bera, R.N.; Sinha, N.B.; Kandar, D.; Bera, R.; and Sarkar, S.K. (2008). Experimental studies and simulations Based prediction of a better MIMO-OFDM combined system for broadband wireless mobile communication. *Progress in Electromagnetics Research C*, 2, 47-64.
11. Muschallik, C. (1996). Improving an OFDM reception using an adaptive Nyquist windowing. *IEEE Transactions on Consumer Electronics*, 42(3), 259-269.
12. Moose, P.H. (1994). A technique for orthogonal frequency division multiplexing frequency offset correction. *IEEE Transactions on Communication*, 42(10), 2908-2914.
13. Chung Y.H. (2008). Inter-carrier interference self-cancellation scheme with Improved bandwidth efficiency for OFDM transmission systems. *International Conference on Convergence and Hybrid Information Technology*, 95-99.
14. Zhao, Li; and Zhang, P. (2006). A new ICI self-cancellation scheme based on repeated symbol in OFDM system. *International Conference on Communications, Circuits, and Systems Proceedings*, 2, 1216-1220.
15. Qiang Shi; Yong Fang; and Min Wang. (2009). A new ICI self-cancellation scheme for OFDM systems. *5th International Conference on Wireless communications, networking and mobile computing*, 1-4.
16. de Abreu, G.T.F.; Ochiai, H.; and Kohno, R.. (2004). Linear maximum likelihood decoding of space-time block coded OFDM systems for mobile communications. *IEE Proceedings-Communications*, 151(5),447-459.
17. Dũng Ngọc Đào; and Tellambura, C. (2005). Intercarrier interference self-cancellation space-frequency codes for MIMO-OFDM. *IEEE Transactions on Vehicular Technology*, 54(5), 1729-1738.
18. Jeruchim, M.C; Balaban, P.; Shanmugan, K.S. (2000). *Simulation of communication systems: Modeling, methodology, and techniques*. (2nd Ed.) Springer.
19. Chiueh, T.D.; and Tsai, P.Y. (2007). *OFDM baseband receiver design for wireless communications*. John Wiley and Sons (Asia) Pte Ltd, Singapore.