

REVIEWING TRAFFIC CONFLICT TECHNIQUES FOR POTENTIAL APPLICATION TO DEVELOPING COUNTRIES

S. M. SOHEL MAHMUD^{1,*}, LUIS FERREIRA¹,
MD. SHAMSUL HOQUE², AHMAD TAVASSOLI¹

¹School of Civil Engineering, The University of Queensland (UQ),
St. Lucia, QLD 4072, Australia

²Department of Civil Engineering, Bangladesh University of Engineering and Technology
(BUET), Dhaka 1000, Bangladesh

*Corresponding Author: s.mahmud@uq.net.au

Abstract

The economic and social costs due to road crashes are disproportionately higher in developing countries. In addition, underreporting, coupled with an incomplete and inconsistent recording of reported crashes is a major issue in such settings. A brief outline of the dimension of road safety problems in developing countries and the most common limitations of existing crash databases is given in the paper. The challenges in applying traditional approaches for traffic safety evaluation and initiatives are also discussed. Diagnosis of road safety problems using traffic conflict techniques has received considerable research interest and has gained acceptance as a proactive surrogate measure in developed countries. Significant studies have been accomplished to develop, validate and apply different surrogate indicators for the estimation of traffic conflicts, as well as an assessment of the safety problem in different road geometric and operating conditions. This has provided a substitute for the historical crash records in traffic safety research. The main objective of this paper is to assess the application potentiality of this surrogate safety measures to address safety issues in developing countries. To do that, this paper critically reviews and synthesizes the different indicators of surrogate safety measures. The main principles, as well as advantages and disadvantages of the major indicators and prospects of application, are presented here. Finally, future research directions for road traffic safety assessment are outlined in the perspective of understanding the most concerning human issue due to traffic crashes in developing countries.

Keywords: Conflict, Developing countries, Road safety, Surrogate measures, Traditional approaches.

Nomenclatures

a_F	Vehicle's acceleration (m/s^2)
a_L	Leading vehicle's acceleration (m/s^2)
D	Initial relative space gap (m)
d_2	Distance between leading vehicle and following vehicle (m)
g	Gravity acceleration (m/s^2)
L	Vehicle length (m)
l	Subject vehicle's length
S	Space distance (m)
S_0	Distance between car 1 and 2
t_1	Leaving time of conflict point
t_2	Coming time at conflict point
t_i	Time (vehicle i passes a certain location)
t_{i-1}	Time (vehicle ahead of vehicle i passes the same location)
V	Vehicle velocity (m/s)
V_1, V_2	Velocity of leading car 1 and following car 2, respectively
V_F	Following vehicle's speed (m/s)
V_L	Leading vehicle's speed (m/s)
v_1	Velocity of following vehicle (m/s)
v_2	Velocity of leading vehicle (m/s)
X	Vehicle position

Symbols

α	Deceleration rate to stop
Δd	Distance to the collision point
Δt	Driver's reaction time 1
μ	Friction coefficient
Δa	Relative Acceleration (m/s^2)
ΔV	Relative speed (m/s)
τ_{sc}	Small time step
δ	Switching variable (0 or 1)

Abbreviations

GDP	Gross Domestic Product
INRETS	Institut National de Recherche sur les Transports et leur Sécurité
RSA	Road Safety Audit
RSI	Road Safety Inspection
TCT	Traffic Conflict Technique
WHO	World Health Organization

1. Introduction

Road crashes cause significant personal suffering and have a devastating effect on social and economic development, principally in developing countries. Low- and middle-income countries' road traffic-related death rates are more than double than those in high-income countries [1]. In spite of progress in international traffic safety work, developing countries road deaths continue to mount and are forecast to increase if current practices continue [2]. Therefore, increased efforts and new initiatives are needed to gain a better understanding of causative factors and to select more appropriate intervention with minimum effort for arresting this on road

epidemic. However, almost all of the road safety initiatives including assessment, selection of intervention and evaluation, are still confined to traditional approaches which rely fully on either historical crash data or personal judgment. However, these traditional evaluation approaches, have significant limitations and application challenges, which are more prevalent in developing countries.

Traffic Conflict Techniques (TCTs) address several issues associated with traditional approaches for safety evaluation. They can provide a deeper understanding of the failure mechanism and chain of event which leads to road traffic collisions and resulting consequences [3]. The most appealing aspect of conflict indicators is their ability to capture conflict data, including severity of collisions, in an objective and quantitative way within a shorter time period compared to accident data. As a result, the analysis is less affected by time-dependent factors. In addition, the problem associated with the recording and compilation of long historical accident data does not apply. Hence, the evaluation of any safety program and the effectiveness of any intervention can also be assessed in a shorter period of time [4].

Since the 1960's, a substantial number of studies have been undertaken worldwide to develop, validate and apply different surrogate indicators for the evaluation of traffic conflicts in different road geometric and operation conditions, as a substitute for the use of historical crash records. A number of proximity measures/indicators have been developed based on time or space proximity to ascertain conflicts objectively. There are promising opportunities to apply those proactive surrogate proximity measures in order to carry out a more comprehensive form of traffic safety evaluation, as well as to assess and predict levels of traffic safety at specific types of traffic facilities in developing countries. The main goal of this paper is to synthesize those measures with a view to potential application in the developing country context. The current paper derives from a part of a broader study on the modelling of overtaking behaviour and the probability of conflicts in two-lane two-way rural highways in developing countries with heterogeneous traffic environment.

The paper has been organized as follows. Firstly, traffic safety problems in developing countries are highlighted. Traditional traffic safety approaches and application challenges are then discussed. This is followed by a discussion of the surrogate safety measures. Subsequently, the major issues related to traffic conflict techniques are highlighted. This is followed by a discussion of the prospect of application of TCTs in non-lane base heterogeneous traffic environments. A brief summary of the potential proximal indicators with the potential to be used in developing countries is also given. Finally, the main conclusions are summarised and avenues for further research are put forward.

2. Safety Problem in Developing Countries

Several studies have highlighted the issues related to road safety around the world, namely; World Health Organisation (WHO) [1], World Health Organisation (WHO) [5], World Health Organisation (WHO) [6], Bhalla et al. [7]. One of the common findings is that the road safety problems in low and middle-income countries are disproportionately higher than in the economically advanced and highly motorized countries. Whilst problems are decreasing in those developed countries in spite of increasing mobility, the trend in crash rates continues to increase in the case of developing countries.

The number of road fatalities declined by 4.3% from 2012 and 7.9% from 2010 among the 32 member countries of International Road Traffic and Accident Database (IRTAD) relative to 2015 [8]. Some striking features of the road safety problems in developing countries are given below:

- Around 91% of road traffic fatalities occurred in low and middle-income countries among the 1.25 million road traffic fatalities worldwide in 2013; while those countries account for 82% of the world's population and only 54% of the registered vehicles [1]. Moreover, more than half of the world's traffic fatalities occur in the Asian-Pacific region although only one-fifth of motorized vehicles are registered in that region [5].
- Vulnerable road users are the major victims, mainly in low and middle-income countries. Among the total road traffic deaths in the world, half are motorcyclists (23%), pedestrians (22%) and cyclists (5%). In Low-income countries, the proportion of vulnerable road users (pedestrians, cyclists and motorcyclists combined) deaths is around 57%; this figure is lower both in middle-income (51%) and high-income countries (39%) [1, 6].
- The economic burden of road traffic crashes is often estimated as high as 1 to 3 percent of GDP. For low and middle-income countries, it is estimated to be up to a very significant 5% of GDP [1].
- It is estimated that road traffic injuries are the eighth leading cause of death globally, with an impact similar to that caused by many communicable diseases, such as malaria [7]. For young people (aged 15–29 years), this is the leading cause of death, which obviously causes a heavy toll on those entering their most productive years. It is also predicted that road traffic deaths will become one of the leading causes of death by the year 2020 particularly for low-income and middle-income countries [5].

3. Traditional Safety Approaches and Challenges for Developing Countries

The review of the existing available literature revealed that most of past research in the field of road safety risk evaluation concerns traditional approaches, particularly in the case of developing countries. These approaches are mainly historical crash data depended, which uses different types of statistical methods and anticipatory estimation approach based on safety inspection and audits [9-11].

3.1. Traditional approaches: historical data

Traffic safety is commonly measured in terms of the number of traffic crashes and their consequences, in terms of life and property losses or severity of crashes. Traditional approaches to traffic safety evaluation, as well as road safety management, include before-after observation, black spot Identification and statistical modelling. Despite having a long history, this well-established approach has some inherent problems associated with it. The first problem is associated with the most dependent and fundamental variable which is historical crash data. It is known that the latter has severe drawbacks in terms of its availability, consistency and quality. A summary of major limitations related to crash data and database is given below:

- Unavailability of the crash and related information is common mainly in developing countries [12, 13].

- Under-reporting is also widespread. Many studies indicate that the range of under-reporting of fatalities is around 2 to 5 percent in developed countries and 25 to 50 percent in developing countries [1, 6, 13].
- Non-fatal crash and injuries are heavily under-registered, even in some developed countries [6]. Some countries report only those crashes that involve injuries or economical losses above a certain cost.
- Reporting biases and accuracy problems of accident data due to incomplete and inconsistent reporting is notably significant [14].
- In many cases, crash statistics do not provide a comprehensive picture of the traffic and safety situation [11]. Most of the crash data also do not capture information on many risk factors such as use of seat belt, helmet or speeding condition, vehicle conditions and weather factors, particularly in crash data of developing countries [15, 16].
- Coding errors throughout the process from the onsite report form filling to the data entry and transfer is a common occurrence [17, 18]. Moreover, despite having a uniform reporting form in many countries, reports are often completed with varying levels of details or ignore important information, such as the exact location of crashes, vehicle movements and injury patterns [19]. This problem often restricts the ability to understand the chain of events of a crash occurrence process and to evaluate the causative factors for selecting target oriented interventions [20].
- Finally, longer collection cycles to gather sufficient data for the analysis demands a sufficiently large number of crashes and eventually deaths, injuries and property losses before any intervention.

In addition, there are some other specific but important issues with each individual method of this general approach [11].

3.2. Traditional approaches: personal judgment

The problems associated with crash databases led to the development of some alternative approaches. The safety of a road is evaluated on the basis of the features of the road and its environment, without recourse to crash records [21]. These approaches could be divided into two broad categories, namely: Road Safety Audit/Inspection (RSA/RSI) and Safe System Approach. However, these approaches are mainly dependant on personal judgement. In addition, some methodological and practical issues are discussed below.

Road safety auditors must have specialist skills in safety audit. Although road safety audit is of particular importance in developing countries, it is almost impossible to implement for the lack of accredited audit professionals, as well as the institutional set-up for accreditation [22]. Moreover, this approach mainly relies on engineering features and does not take into account other important descriptive variables, such as vehicle condition.

The safe system assessment approach is relatively new and provides the capability of assessing a wide variety of projects subjectively [23]. This approach, which has grown from the safety audit process, is not free from the problem associated with the RSA/RSI, particularly in the context of developing countries. The success and challenges of the safe system are still under evaluation.

4. Surrogate Safety Measures

The challenges related to historical data based approaches are critical in the context of developing countries. Therefore, many ways of commissioning non-accident data have been proposed. These include speed variances, erratic manoeuvres, traffic violence, and traffic conflicts [24]. Among these surrogate measures, using traffic conflict techniques (TCTs) for diagnosing road safety problems has gained acceptance as a proactive surrogate measure [25, 26].

A significant number of studies have been reviewed for the development and application of different indicators to evaluate the traffic conflicts in different road geometric and operational environment. This is seen as a substitute for the use of historical crash records. The following sections provide a brief review of the development, application and related issues of traffic conflict techniques.

4.1. The concept and underlying theories of TCT

The term "conflict" in traffic research was first given by Perkins and Harris [27], to identify safety problems related to vehicles. The concept was based on the observation of different occurrences in which a vehicle took evasive action to avoid a probable collision. Such actions are to be identified by some observable responses, which assume the presence of critical situations made by drivers, such as hard braking or a sudden changing of lanes, etc.

The need to add a subjective scale for measuring the severity of conflicts as a was first reported by Spicer [28]. Van der Horst and Kraay [29] focused on "situations where two road-users would have collided had neither of them made any kind of aversive manoeuvre. The point at which the aversive action is taken is recorded through observation as the "Time-to-Accident" (TA). The TA value together with the conflicting speed is used to determine whether or not a conflict is "serious"."

The definition of traffic conflict techniques or TCTs process suggests a hierarchical continuum representation between conflicts and collisions. Many researchers suggested several typical models to present the concept of a degree of severity in a continuum representation. Amundson and Hydén [30] illustrated accidents as a subset of serious conflicts. Glauz and Migletz [31] presented a distribution function in terms of nearness to a collision to order severity scales. One of the most accepted intuitive diagrams was introduced by Hydén [32] in the form of a pyramid. Accidents are placed at the top level of pyramid followed by safe driving with few interactions at the bottom level.

4.2. Defining criteria

Almost all of the practising definitions of traffic conflicts can be group into two types, namely: traffic conflict based on evasive action; and traffic conflict based on temporal (and (or) spatial) proximity.

4.2.1. Traffic conflicts based on evasive actions

Under this criterion, a traffic conflict is defined by the appearance of evasive actions. A definition of evasive action based traffic conflict is:

"... an event involving two or more road users, in which the action of one user causes the other user to make an evasive manoeuvre to avoid a collision" [33].

In this definition, conflicts have been related to such occurrences as the appearance of brake lights or the unexpected changing of lanes or direction. In order to identify a traffic conflict, these types of evasive actions have to be readily observable. A number of subsequent conflict studies have been undertaken following the same methodology in many countries [33-35]. According to this definition, conflicts and crashes are analogous in nature, except there is a successful evasive action in the conflict.

Different issues regarding the observations of conflict based on evasive action have been pointed out by different authors, e.g., Chin and Quek [4] and Zheng et al. [25]. Conflict evaluation based on these evasive actions may result in a diversified way of defining, identifying and interpreting conflicts. Firstly, as field workers can clearly be acquainted with what is to be observed, a list of the possible associated evasive actions must be specified. Without the aid of advanced techniques, this approach has been challenged on many accounts. Furthermore, it is proven that all the specified driver actions are necessarily not evasive in nature. For example, drivers may have applied the brakes as a precautionary action to reduce the potential risk, not as an evasive action to avoid a collision. Differentiating a precautionary action from a truly evasive need to be well addressed, though it can be difficult when a quick assessment is demanded on the spot.

Relating evasive actions with conflicts may also present some difficulties when a conflict is used as a surrogate to a crash. It is argued that crashes are preceded by conflicts, which essentially suggests that conflicts based on evasive actions must exist preceding to the occurrence of a crash. However, this argument has often been questioned, as many of crashes and near misses occur because drivers have failed to take any action in the first place. Moreover, evasive actions are sometimes may not be present in many critical situations. Some of the verified 'evasive' actions are just precautionary, such as braking or lane changing, which do not indicate a dangerous situation [4]. Therefore, there may not have a good correlation between crashes and conflicts if the conflicts are defined based on only observed evasive actions. However, such correlation is often used to support the predictive validity of traffic conflict techniques.

4.2.2. Traffic conflict based on temporal proximity

The closer vehicles are to each other, either in space or time, the nearer they are to a collision. A definition of proximity-based traffic conflict was given by Amundson and Hyden [30]:

“A traffic conflict is a situation involving one or more vehicles where there is imminent danger of a collision if the vehicle (or another road user) movement continue unchanged.”

One of the major advantages of this definition is that all collisions will be preceded by conflicts. In addition, this method is more objective, as conflicts could be measured quantitatively. The quantitative measurement is relatively objective and provides an interpretable quantitative measure in terms of closeness to the collision. Moreover, space or time proximity definition is easily understood.

Several types of proximity indicators have been proposed to evaluate safety in different traffic, operational and geometric conditions [24, 25, 36]. These indicators

can be broadly categorized into two groups, namely: temporal and non-temporal. The non-temporal measures can also be categorized according to distance and deceleration amongst other variables. Table 1 provides a summary of existing proximal indicators.

Error! Reference source not found. demonstrates a synopsis of the evaluation process for traffic conflict indicators (abbreviations of acronyms and references are same as in Table 1).

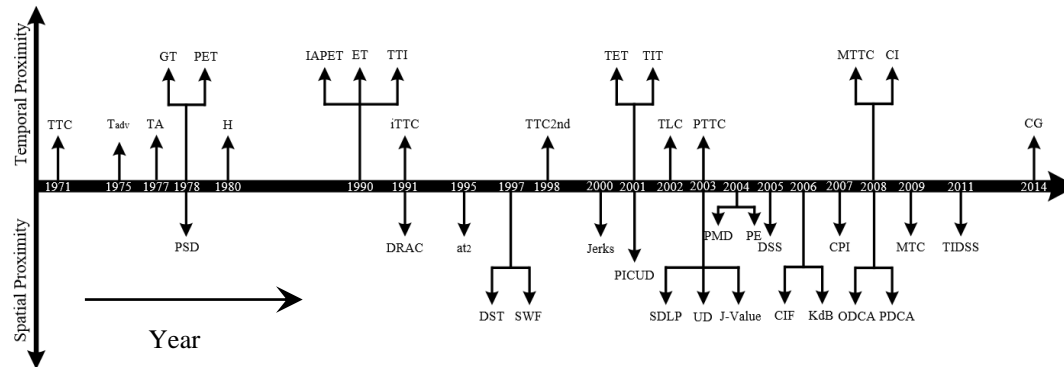

Fig. 1. Evaluation of traffic conflict indicators.

Table 1. A summary of the existing proximal indicators.

Type	Indicators name
Temporal Proximity Based	Time-to-Collision (TTC) or Time-Measured-to-Collision (TMTC) [37]; Time Advantage (Tadv) [38]; Time-to-Accident (TA) [39]; Gap time [40] ; Post-Encroachment Time (PET) [40]; Headway (THW/H) [41]; Initial Attempted Post Encroachment Time (IAPET) [42]; Enchroachment Time [42]; Time to Intersection/Stop Line (TTI) [43]; Inverse of time-to collision (iTTC) [44]; The Second Order Predicted TTC (TTC 2nd) [45]; Time Exposed Time-to-Collision (TET) [46]; Time Integrated Time-to-Collision (TIT) [46] ; Time to Line Crossing [47]; Time to Line Crossing [48]; Modified Time-to-Collision (MTTC)[49]; Crash index (CI) [49] ; Critical Gap [50].
Distance-Based	Proportion of Stopping Distance (PSD) [40]; Potential Index for Collision with Urgent Deceleration (PICUD) [51]; Unsafe Density (UD) [52]; Predicted minimum distance (PMD) [53]; Difference of Space Distance and Stopping Distance (DSS) [54]; Margin to Collision (MTC) [55]; Time Integrated DSS (TIDSS) [56].
Deceleration Based	Deceleration Rate to Avoid the Crash (DRAC) [57]; Dispersion of Acceleration during Unit Time in Unit Road Section [56, 58]; Deceleration of Safety Time (DST) [59]; Criticality Index Function (CIF) [60]; Crash Potential Index (CPI) [61]; Overt Deceleration for Collision Avoiding (ODCA) [62]; Potential Deceleration for Collision Avoiding (PDCA) [62].
Others	Shock-Wave Frequency (SWF) [63]; Composite g-force and speed (Jerks) [64]; Standard Deviation of Lateral Position (SDLP) [65]; An accumulative safety indicators (J-value) [66]; Potential Energy (PE) [67]; Judgement Line of Brake Initiation (KdB) [68, 69].

Indicators based on temporal proximity are popular because they integrate both the spatial proximity and speed. Using the values of traffic movement parameters in a specified equation, traffic conflicts can be recorded once the output is less than a predetermined threshold [26, 70].

Although proximity measures play an important role in traffic conflict techniques, there are still some important issues related to these measures. For example, there is still no consensus on what measures should be given priority [71]. Various measures are diverse in nature and their preferred application also differs. Therefore, on many occasions, it is suggested that several measures should be used jointly [72, 73].

Moreover, almost all of the measures are limited to the estimation of crash risk. The level of severity and the possible consequences of a potential crash is not accounted for [74]. Therefore, severity analysis of a conflict is difficult to distinguish the consequences, when all traffic events are considered in a safety continuum [25].

Moreover, many of the measures assume the “unchanged speed and direction” for predicting probable conflict. Some experiments have assumed unchanged direction and constant acceleration or deceleration. However, due to the complex nature of traffic behaviour, these simple assumptions may not be realistic in some cases [75].

Most of the past applications of conflict measures have been based on lane based homogeneous traffic environments. Therefore, the extent to which these measures would be applicable in the non-lane base heterogeneous and/or rural roads traffic environments is yet to be tested. Finally, most of the conflict measures have focused on the rear-end or right-angle collisions. Some studies have been considered merging and diverging collisions, particularly in motorway/freeway of developed countries, i.e., St-Aubin [10]. Application of this measures for head-on collision measurement is very rare. It is not known the extent to which these measures would be useful for the evaluation of head-on or overturning conflicts in rural road environments, particularly using conventional traffic data collection techniques.

4.2.3. Threshold values

Different researchers have used different threshold values of different indicators to distinguish between relatively safe and critical encounters. Generally, TTC lower than the perception and reaction time of the drivers is suggested to consider unsafe. For approaches at intersections, Van der Horst [43] and Vogel [65] both suggested that minimum TTC value will be 1 second but their desired values are 1.5 and 2 seconds respectively. For 2-lane rural roads, American Association of State Highway Transportation Officials (AASHTO) [76]; Farah et al. [77] and Hegeman [78] all suggested the critical threshold value should be 3 seconds. In case of critical TA value, initially a single TA value 1.5 seconds was used to distinguish serious conflict and slight conflict [30].

Later, Shbeeb [79] shown that the 1.5 seconds limit appeared to work well in urban areas when the speed is low, but not in rural areas where speed is higher. Different countries use different headway values to follow a vehicle safety. In the USA, it is not less than less than 2s [80]. On the other hand, in Germany is recommended minimum headway distance should be “half the speedometer”,

which means in the case of 80 km/h speed, the minimum distance should be at least 40 m i.e. 1.8s. On the other hand, in many European countries, it is recommended a safe headway of 2 seconds [65]. In case of PET, the threshold value less than 1.0 or 1.5 seconds are considered critical [29, 81, 82-84]. However, Songchitruksa and Tarko [85] shown that for site aggregated crash count a 6.5s threshold value gives the best-fitted model.

In case of DRAC, American *Association of State Highway Transportation Officials* (AASHTO) [86] DRAC recommended $3:40 \text{ m/s}^2$ for most drivers. Archer [84] suggests if a vehicle exceeds value of $3:35 \text{ m/s}^2$, that is a conflict. Guido et al. [87] also considered this value in his study and evaluated the risk of conflict.

4.3. The validity and reliability of TCTs

The validity of TCTs is based on whether there is a correlation between a traffic conflict and the actual crash record. Some studies have also considered the validity as the prediction potentiality of the expected number of crashes on a particular location [4, 25].

A number of early studies have found that the correlation between a conflict and a crash is not statistically significant. For instance, Williams [88] questioned the use of TCT as they found a poor relationship between it and conflict-related exposure. In a developing country perspective, Tiwari et al. [89] studied 14 locations in Delhi, India and tried to develop a relationship between mid-block fatal crashes and conflict rates but found a weak crash-conflict association.

On the other hand, a number of studies showed a strong relationship between traffic conflicts and actual crashes [3]. A few recently conducted studies (e.g., [26, 11]), have used advanced data collection techniques, including automated observation through computer vision, to show that there is a strong relationship between traffic conflict and crashes.

The reliability of TCTs is another concern in relation to the method of conflict measurement, more precisely data collection and conflict evaluation technique [4, 11]. Earlier conflict detection methods were designed based on the notion that conflict would be measured in terms of the action of driver, as a subjective judgment. These methods relied on the human observer and they have been criticized on reliability grounds [4, 90].

More recently, quantitative methods based on surrogate safety measured have been used. However, measurement of parameters, such as absolute and relative speed, distance, acceleration, deceleration and potential conflict point, can pose a challenge. Video analysis has been introduced to address this problem, as well as to improve the reliability of data collection. Issues related to camera adjustment, coverage of camera, the transformation of the image from three to two dimensions, and dependency on human observations in extracting data from video, are still major constraints to obtain accurate data [11, 84].

Therefore, for automatic description of conflict without human observer dependency, researchers are now working on video sensors and computer vision techniques [26]. In this regard, application of microsimulation models for safety evaluation has also opened a new spectrum for improving the reliability of conflict

studies. Integration of advanced machine vision technique along with micro-simulation modelling is also held potential in understanding the most concerning traffic safety problems [91]. There are a couple of notable studies in the field of surrogate safety evaluation using traffic safety micro-simulation (e.g., Archer [84], Yang [11], Cunto [92]) However, there is still a significant void in the development and application of simulation models to evaluate traffic safety of non-lane based heterogeneous traffic environments.

5. Indicators Potential for Developing Countries

In contrast to conditions in developed countries, non-lane based heterogeneous traffic conditions are common in developing countries with significant numbers of vulnerable road users, including pedestrians and non-motorized vehicles. The road geometric and traffic operating conditions in many developing countries is very complex and in nature with a wide variety of characteristics in operation and performance of vehicles [93]. On the other hand, all the past research and application of conflict techniques have been developed mainly based on lane based car dominated homogeneous traffic conditions.

However, subjective observation and judgment approaches for conflict evaluation which are mainly based on the evasive action can easily be applied in any traffic situations of developing countries. As far as the authors aware, the first attempt at assessing traffic safety in developing countries using traffic conflict technique were made by INRETS research team in 1993 [34]. They carried out an extensive road safety study in the Philippines using simple conflict observational technique. Conflict was defined by trained observers adapting The French Conflict Technique (conflict based on subjective judgement) [94].

Other than the subjective approach, around 40 proximal indicators have been proposed for lane-based traffic conditions. Although the application of those indicators in developing countries' traffic environment is very rare, or not describe in the literature properly, many of those indicators are also directly applicable to developing countries traffic environment and can be gainfully used for traffic safety evaluation. In 1994, Almqvist and Hydén [95] first applied proximity based technique i.e. Swedish Traffic Conflict Technique (conflict observation using TA, the time between evasive action and time-to-accident) [96] in the city of Cochabamba in Bolivia with a view to guiding a method to assess the safety problem in developing countries. The study indicated that the technique is useful in its present form for this condition. Tiwari et al. [89] evaluated conflicts at 14 locations in Delhi, in a heterogeneous traffic environment. The conflict was evaluated using the concept of Time-to- accident (TA). This study recorded seven types of conflicts occurring at mid-block in heterogeneous traffic, such as head-on, rear-end, sideswipe, change direction, fixed object, angle and traverse angle. However, the study did not find any conclusive relationship between conflict and crash. Farah et al. [77] evaluated risk of passing manoeuvre on rural two-lane highways using Time to Collision (TTC).

Recently, Buddharaju et al. [97] applied an adapted version of the Traffic Conflict Techniques (number of times a horn is used) to evaluate conflict as well as to assess the main causes of accidents on Indian roads. The study tried to show a relationship between conflict and accident in different intersections of a small city

in India. More recently, Vedagiri and Killi [98], has to define conflict on at-intersection with mixed traffic condition in India using a modified methodology of measuring Post Encroachment Time (PET). However, most of the established surrogate proximal safety indicators have not yet been explored in developing countries traffic environment. Whereas, many of those indicators could be a better replacement of traditional crash database safety evaluation and management approaches in developing countries. Table 2 presents a summary of some surrogate proximity indicators, which have the potential to be applied in developing countries. Nomenclatures of the equations are given at the beginning of the paper.

Table 2. Surrogate indicators potential for developing countries.

Indicator	Computational equation	Suitability for developing countries	Suitable for crash type
Temporal Proximity			
Time-to-Collision (TTC) [37]	$TTC_i(t) = \frac{X_{i-1}(t) - X_i(t) - l_i}{V_i(t) - V_{i-1}(t)}$	More frequently used and applicable in different traffic environments, including work zone safety; easy to measure either manually or by video analysis; Applicable for crash studies with different users including VRUs; many automobile collision avoidance or driver assistance systems have used it as an important warning criterion	Rear-end, head-on, turning/weaving, hit objects/parked vehicle, crossing, hit pedestrian
Time-to-Accident (TA) [39]	$TA = \frac{\Delta d}{v_i}$	Same as TTC	Same as TTC
Headway (H) [41]	$H = t_i - t_{i-1}$	Easy to measure; applicable for all environment; level of risk could be distinguished	Rear-end mainly, other such as turning, hit objects/parked vehicle
Post-Encroachment Time (PET) [42]	$PET = t_2 - t_1$	More suitable for intersecting conflicts; easy to extract; can be easily estimated using photometric analysis in video or simulated environment; represents driver behaviour	Mainly for right angle or crossing crash, hit pedestrian rear-end, head on also
Time Exposed Time-to-Collision (TET) [46]	$TET_i^* = \sum_{t=0}^T (\delta_i(t) \cdot \tau_{sc})$	Can be calculated separately for each user class; applicable in the comparison of a do-nothing case with an adopted situation; suited in microscopic simulation studies; easy to include small TTC value due to the inclusion of time-dependent TTC values for all subjects.	Same as TTC
Time Integrated Time-to-Collision (TIT) [46]	$TIT_i^* = \sum_{t=0}^T [TTC^* - TTC_i(t)] \cdot \tau_{sc}$	Level of risk or probability of collision can be derived; others same as TET	Same as TTC
Modified Time-to-Collision (MTTC) [49]	$MTTC = \frac{-\Delta V \pm \sqrt{V^2 + 2\Delta a D}}{\Delta a}$	More advance than TTC; Considers driving discrepancies; severity of the collision could be weighted using CI indicators	Vehicle-vehicle crash

Crash index (CI) [49]	$CI = \frac{\{(V_F + a_F.MTTC)^2 - (V_L + a_L.MTTC)^2\}}{2} \times \frac{1}{MTTC}$	Reflects the severity of a potential crash; describes speed influence on kinetic energy in collisions; the elapsed time are considered before occurring conflict; Severity and the likelihood of a potential conflict could be interpreted	Same as MTTC
Non-temporal Proximity indicators			
Potential Index for Collision with Urgent Deceleration(PICUD) [51]	$PICUD (m) = \frac{V_1^2 - V_2^2}{2\alpha} + S_o - V_2\Delta t$	More suitable than TTC for evaluating the risk of collision of the similar speeds consecutive vehicles.	Same as TTC
Proportion of Stopping Distance (PSD) [40]	$PSD = \frac{RD}{MSD}$	Single vehicle conflict with fixed or moving objects can be evaluated; easy for observation and calculation.	Hit object (on road or road side), overturning
Difference of Space Distance and Stopping Distance (DSS) [54]	$DSS = \left(\frac{v_1^2}{2\mu g} + d_2 \right) - \left(v_2\Delta t + \frac{v_1^2}{2\mu g} \right)$	The calculation formula and threshold value are simple and clear	Rear-end, hit object, turning
Deceleration Rate to Avoid the Crash (DRAC) [57]	$DRAC_{FV,t+1}^{REAR} = \frac{(V_{FV,t} - V_{SV,t})^2}{(X_{SV,t} - X_{FV,t}) - L_{SV,t}}$	Explicitly considers the role of differential speeds and decelerations in traffic flow; suitable for rear-end conflict during following or passing	Rear-end, Hit object/parked vehicle, Hit pedestrian, Merging and diverging manoeuvres

Time to Collision (TTC) is frequently used in practice in preference to many other established measures for theoretical and reliability reasons. Though, TTC is not an appropriate surrogate safety indicator for the measurement of lane changing lateral conflicts, as it has been developed using the concept of point conflict [99], it could be potentially applied on two-lane highways or single lane roads in developing countries, where the effect of lane change or lane changing lateral conflict is insignificant. Time to Accident (TA) is an evasive action based indicator by which vehicle to vehicle; single; and multi-vehicle conflicts can be evaluated [100]. The TTC and TA indicators are suitable for measuring different types of conflicts, such as rear-end; head-on; hitting a fixed-object/parked vehicle; hitting pedestrian and collision during turning at an intersection. These are all predominant in developing countries Time headway (TH) is used to estimate the criticality of a follow-up traffic situation, which is applicable in all traffic environments [101].

Post-Encroachment Time (PET) is more appropriate for intersection conflicts assessment. A number of studies have used this indicator [84, 99] and this could potentially be applied in urban intersections in developing countries. Moreover, TET (Time Exposed Time-to-collision) and TIT (Time Integrated Time-to-collision) extended from TTC could be useful for evaluating probability and level of severity of crashes. Another extension of TTC is modified time to collision (MTTC) proposed by Yang [11]. This considers driving discrepancies and is also applicable in a developing country context. Crash Index (CI) is useful for weighting severity of the collision.

In addition, some non-temporal indicators that explain spatial or kinematic characteristics of vehicle interactions have the potential to be applied in developing countries, particularly for hit object or pedestrian, rear-end conflict analysis. Potential Index for Collision with Urgent Deceleration (PICUD) is more suitable than TTC for evaluating the risk of collision of the similar speeds consecutive vehicles [102]. Many researchers have clearly recognized the prominence of DRAC as a safety-performance indicator, as it explicitly considers the role of differential speeds and decelerations in traffic flow; e.g., [84, 99, 103]. The difference between the Space and Stopping Distance (DSS) is a simple but useful measure for calculating rear-end collision and potentially applicable to different traffic environment. Using Proportion of Stopping Distance (PSD) indicator, single vehicle conflict with fixed or moving objects can be evaluated. It is relatively easier for observation and calculation.

Although many of these indicators have not been tested and validated in developed countries, their use to date indicates that they might be useful for such environments. However, very often developing countries have some complex and unique road and geometric characteristics and traffic behaviour. Local peculiarities include some special types of single-vehicle crashes, such as overturn induced by pothole; shoulder drops and bridge approach drops, tyre burst induced by overloading and overuse of tyres. In addition, numbers of crashes in developing countries are triggered by road hazards, including roadside encroachment, roadside activities by local users. Addressing these issues in traffic conflict techniques remain a challenge.

6. Conclusions

6.1. Summary

The application of surrogate safety measures has a long history in terms of development, research and application. Earlier reliance solely on the subjective judgement was followed by the use of more objective proximal based safety indicators.

This paper provides a discussion of the different indicators of surrogate safety with potential application in developing countries. Two major important issues related to traffic conflict technique are highlighted. One is the concept and underlying theories of the surrogate measures and the other is validity and reliability of the traffic conflict techniques used. The paper has shed some light on the strengths and weakness of various traffic conflict techniques and their application.

In spite of significant research and application on the use of TCTs, there are still significant opportunities to improve their application, particularly in non-lane based heterogeneous traffic environments prevalent in developing countries. With this view, some future research directions are outlined below to provide wider application of these techniques with more accuracy and reliability.

6.2. Future research directions

Traffic conflict techniques have been widely used and the development of surrogate safety measures is seen as one of the most promising research areas. Nevertheless, there are some important gaps, which could benefit from further research.

- **Application in traffic environment of developing country:** Non-lane based heterogeneous traffic with the presence of slow-moving non-motorized and two-wheelers vehicle are prevalent in many developing countries. Nevertheless, more application in non-lane base heterogeneous rural traffic environment will offer a wider perspective in understanding and application of TCT for safety evaluation.
- **Definition of standard threshold values for different traffic environments:** No standard threshold value has been determined to distinguish conflict and normal events. There is scope for future research on the selection of an appropriate threshold values for different standard indicators, as those values might be dependent on the driver, the road and the traffic environment.
- **Exploring correlation between conflicts and real crashes for diverse traffic environments:** Las t few years, a couple of statistical approaches have been taken to relate traffic conflict and crash using advanced econometric model [25]. Although these models are providing an appealing theoretical foundation, they still need to be further tested and validated. New methods or models could be explored for heterogeneous traffic environments in developing countries to validate the TCTs.
- **Single or more than two vehicle crashes:** Very few studies have focused on a conflict involving single or multi vehicles like overturning or out of road crashes [104]. Therefore, further research is needed on how to determine and validate conflicts involving single vehicles, for example, overturning crash due to different reasons or crash involving multi-vehicles.
- **Conflicts during overtaking:** Farah et al. [105] evaluate the risk of passing vehicle rear-end conflict using simulator data. Shariat-Mohaymany et al. [70] evaluate head-on conflict using inductive loop detector data on a particular point of roadway segment. The study is needed on the use of surrogate measures to evaluate overtaking behaviour and conflict risk during overtaking manoeuvre on a segment of the road using empirical data.
- **Micro-simulation modelling approach considering developing countries traffic environment:** Using micro-simulation model for safety analysis is still based on traffic environments in developed countries.. Real life testing is relatively more difficult in developing countries traffic environment due to lack of expertise, available data and resources. Research on the development of traffic safety micro-simulation models is, therefore, more critical in developing countries. Use of traffic conflict as a surrogate safety measure to develop micro-simulation model could be a milestone in traffic safety research in developing country.

Finally, integration of advanced computer vision technique with micro-simulation modelling has the potential to establish a better theoretical and operational foundation of traffic conflict techniques. The application of such new approaches to traffic environments in developing countries, may lead to advances in traffic conflict studies and hence reduce the high crash rates in those countries.

References

1. World Health Organisation (WHO). (2015). *Global status report on road safety*, Geneva, Switzerland.

2. World Health Organisation (WHO). (2009). *Global status report on road safety: Time for action*, Geneva, Switzerland.
3. Sayed, T.; and Zein, S. (1999). Traffic conflict standards for intersections. *Transportation Planning and Technology*, 22(4), 309-323.
4. Chin, H.-C.; and Quek, S.-T. (1997). Measurement of traffic conflicts. *Safety Science*, 26(3), 169-185.
5. World Health Organisation (WHO). (2004). *World report on road traffic injury prevention*, Geneva, Switzerland.
6. World Health Organisation (WHO) (2013). *WHO global status report on road safety: Supporting a decade of action*, Geneva, Switzerland.
7. Bhalla, K.; Shotten, M.; Cohen, A.; Brauer, M.; and Shahraz, S. (2014). *Transport for health: The global burden of disease from motorized road transport*. Global Road Safety Facility (GRSF), Washington D.C., United States of America.
8. The Organisation for Economic Co-operation and Development (OECD) (2015). *Road safety performance in 2013 and 2014. Road Safety Annual Report*. Paris: OECD Publishing.
9. Roper, P.; and Turner, B. (2008). Why do we need to take a risk assessment based approach in road safety? *Proceedings of the 23rd Australian Road Research Board (ARRB) Conference*. Adelaide, Australia. 6 pages.
10. St-Aubin, P.G. (2012). *Traffic safety analysis for urban highway ramps and lane-change bans using accident data and video-based surrogate safety measures*. Master Thesis. Department of Civil Engineering and Applied Mechanics, McGill University, Montréal, Canada.
11. Yang, H. (2012). *Simulation-based evaluation of traffic safety performance using surrogate safety measures*. Ph.D. Thesis. Graduate School, University Rutgers, The State University of New Jersey, New Brunswick, United States of America.
12. Transport Research Laboratory (TRL). (2003). *Bangladesh road crash costing discussion document*. Crowthorne, United Kingdom.
13. Hoque, M.M.; and Mahmud, S.M.S. (2009). Road safety engineering challenges in Bangladesh. *Proceedings of the 13th Road Engineering Association of Asia and Australasia (REAAA) Conference*. Seoul, Korea, 10 pages.
14. Evgenikos, P.; Holder, Y.; Ivers, R.; Jacobs, G.; Jan, S.; Khayesi, M.; Peden, M.; and Yanis, G. (2010). *Data systems: A road safety manual for decision-makers and practitioners*, World Health Organisation (WHO), Geneva, Switzerland.
15. Australian Transport Council (ATC). (2011). *National Road Safety Strategy 2011-2020*, Canberra, Australia.
16. Pham, M.H., Mouzon, O., Chung, E., and El Faouzi, N.E. (2008). Sensitivity of road safety indicators in normal and crash cases. *Proceedings of the 10th International Conference on Application of Advanced Technologies in Transportation*. Athens, Greece.
17. Organisation for Economic Cooperation and Development (OECD). (1997). *Road safety principles and models: review of descriptive, predictive, risk and accident consequence models*. Paris, France.

18. Accident Research Institute (ARI). (2010). *Road accident in Bangladesh: problem of data analysis (Internal report, unpublished)*. University of Engineering and Technology (BUET), Dhaka, Bangladesh.
19. Alam, M.J.B. (2003). Use of accident data and accident database. *Proceedings of the Workshop on Accident Database Development*. Accident Research Centre (ARC), Bangladesh University of Engineering and Technology (BUET). Dhaka, Bangladesh, 9 pages.
20. Mahmud, S.M.S.; Hoque, M.S.; and Qazi, A.S. (2009). Road safety problems in Bangladesh: some major initiatives, constraints and requirements. *Transport and Communications Bulletin for Asia and the Pacific*, 79, 61-89.
21. Job, S. (2012). Advantages and disadvantages of reactive (black spot) and proactive (road rating) approaches to road safety engineering treatments: When should each be used? *Proceedings of the Australasian Road Safety Research Policing Education Conference*. Wellington, New Zealand, 9 pages.
22. Hoque, M.M. (1997). *Road safety audit in developing countries*. Transportation research group. Department of Civil and Environment Engineering, University of Southampton, United Kingdom.
23. Turner, B.; Jurewicz, C.; Pratt, K.; Corben, B.; and Woolley, J. (2016). *Safe system assessment framework*. Sydney, 68 pages.
24. Debnath, A.K.; Adrian, W.; and Narelle, H. (2014). Proactive safety assessment in roadwork zones: A synthesis of surrogate measures of safety. *Proceedings of the Occupational Safety in Transport Conference*. Gold Coast, Australia, 10 pages.
25. Zheng, L.; Ismail, K.; and Meng, X. (2014). Traffic conflict techniques for road safety analysis: Open questions and some insights. *Canadian Journal of Civil Engineering*, 41, 633-641.
26. Sayed, T.; and Zaki, M.H. (2013). Automated safety diagnosis of vehicle-bicycle interactions using computer vision analysis. *Safety Science*, 59, 163-172.
27. Perkins, S.R.; and Harris, J.I. (1967). *Traffic conflict characteristics, signalized intersections*. Research Laboratories, General Motors Corporation.
28. Spicer, B.R. (1973). *A study of traffic conflicts at six intersections*. Transport and Road Research Laboratory (TRRL), Wokingham, Berkshire United Kingdom.
29. van der Horst, A.R.A. and Kraay, J.H. (1986). *The Dutch conflict technique doctor*. Institute for Road Safety Research (SWOV), Leidschendam, The Netherlands.
30. Amundson, F.; and Hydén, C. (1977). *Proceedings of the First Workshop on Traffic Conflicts*. Institute of Transport Economics. Lund Institute of Technology, Oslo, Norway.
31. Glauz, W.D.; and Migletz, D.J. (1980). *Application of traffic conflict analysis at intersections*. Transportation Research Board, Washington, DC, USA.
32. Hydén, C. (1987). *The development of a method for traffic safety evaluation: The Swedish traffic conflicts technique*. Ph.D. Thesis. Department of Traffic Planning and Engineering, Lund University, Sweden.
33. Parker Jr, M.R.; and Zegeer C.V.(1989). *Traffic conflict techniques for safety and operations. Observers manual*. Federal Highway Administration (FHWA), McLean, Virginia.

34. Muhlrads, N. (1993). Traffic conflict techniques and other forms of behavioural analysis: Application to safety diagnoses. *Proceedings of the 6th ICTCT Workshop*. Salzburg, Austria, 48-64.
35. Phillips, R.O.; Hagman, T.B.R.; and Sagberg, F. (2011). Reduction in car-bicycle conflict at a road-cycle path intersection: Evidence of road user adaptation? *Transportation Research Part F: Traffic Psychology and Behaviour*, 14(2), 87-95.
36. Highways Research Group (HRG) (2007). *Conflict study-application in highways agency road safety*. Chetwynd Business Park, Chilwell, Nottingham, United Kingdom.
37. Hayward, J.C. (1971). *Near misses as a measure of safety at urban intersections*. Master Thesis. Department of Civil Engineering, Pennsylvania State University, United States of America.
38. Hansson, A. (1975). *Studies in driver behaviour, with applications in traffic design and planning: Two examples*. Tekniska Högskolan, Lund, Sweden.
39. Hydén, C. (1977). *A traffic-conflict technique for determining risk*. University of Lund, Lund Institute of Technology Lund, Department of Traffic, Planning and Engineering, Sweden.
40. Allen, B.L.; and Shin, T. (1978). Analysis of traffic conflicts and collisions. *Report No. TRR 667, 67-74*. Transportation Research Board.
41. von Buseck, C.R.; Evans, L.; Schmidt, D.; and Wasielewski, P. (1980). Seat belt usage and risk taking in driving behavior. SAE Technical Paper 800388. *Proceedings of the Automotive Engineering Congress and Exposition*. Detroit, 5 pages.
42. Ghaffari, M. (1990). *A stochastic computer simulation of traffic conflicts*. Ph.D. Thesis. University of Illinois, Chicago.
43. van der Horst, A.R.A. (1990). *A time-based analysis of road user behaviour in normal and critical encounters*. Ph.D. Thesis. Faculty of Electrical Engineering, Mathematics and Computer Science, Delft University of Technology, Netherlands.
44. Chin, H.C.; Quek, S.T.; and Cheu, R.I. (1991). Traffic conflicts in expressway merging. *Journal of transportation engineering*, 117(6), 633-643.
45. Barber, P.; and Clarke, N.J. (1998). Advanced collision warning systems. *Proceedings of the IEEE Colloquium on Industrial Automation and Control: Applications in the Automotive Industry*. London, United Kingdom, 2/1-2/9.
46. Minderhoud, M.M.; and Bovy, P.H. (2001). Extended time-to-collision measures for road traffic safety assessment. *Accident Analysis and Prevention*, 33(1), 89-97.
47. Vogel, K. (2002). *Modelling driver behaviour-a control theory based approach*. Ph.D. Thesis. Studies in Science and Technology. Institute of Technology, University of Linköping, Sweden.
48. Wakabayashi H.; Takahasyi, Y.; Nimi, S.; and Renge, K. (2003). Traffic conflict analysis using vehicle tracking system/digital vcr and proposal of a new conflict indicator. *土木計画学研究・論文集*, 20(4), 949-956.
49. Ozbay, K.; Yang, H.; Bartin, B.; and Mudigonda, S. (2008). Derivation and validation of new simulation-based surrogate safety measure. *Proceedings of*

the Transportation Research Board's 87th Annual Meeting. Washington D.C., 105-113.

50. Cao, X.; Young, W.; Sarvi, M.; and Aghabayk, K. (2014). Automatic discrimination of traffic conflicts during lane changing manoeuvres. Research driving efficiency paper. *Proceedings of the 26th ARRB Conference*. Sydney. New South Wales, Australia.
51. Iida, Y; Uno, N.; Itsubo, S.; and Sukanuma, M. (2001). Traffic conflict analysis and modeling of lane-changing behavior at weaving section. *Proceedings of the Infrastructure Planning*. 24(1), 305-308.
52. Barceló, J.; Dumont, A.-G.; Montero, L.; Perarnau, J.; and Torday, A. (2003). Safety indicators for microsimulation-based assessments. *Proceedings of the Transportation Research Board 82nd Annual Meeting*. Washington D.C., United States of America, 1-18.
53. Polychronopoulos, A.; Tsogas, M.; Amditis, A.; Scheunert, U.; Andreone, L.; Tango, F. (2011). Dynamic situation and treat assessment for collision warning systems: The EUCLIDE approach. *Proceedings of the IEEE Intelligent Vehicles Symposium*. Parma, Italy, 636-641.
54. Japan Society of Traffic Engineers (JSTE). (2005). *Traffic engineering handbook*, Japan.
55. Kitajima, S.; Takatori, O.; Enokida, S.; Takeda, K.; and Katayama, T. (2009). Estimation of driver's dangerous states of rear-end collision based on driver video recorder data and ordinary driving data, , No. 97. *Proceedings of Automotive Engineers of Japan*.
56. Okamura, M.; Fukuda, A.; Morita, H.; Suzuki, H.; and Nakazawa, M. (2011). Impact evaluation of a driving support system on traffic flow by microscopic traffic simulation. *Advances in Transportation Studies*, Special Issue, 99-102.
57. Sverker, A.; Christer, H.; and Ralf, R. (1991). Use of speed limiters in cars for increased safety and a better environment. *Transportation Research Record. Journal of the Transportation Research Board*, (1318), 34-39.
58. Noda, K.; Imai, M.; Ogino, H.; and Kurimoto, Y. (1995). Predictor model of acceleration noise and traffic accident in consideration of road traffic conditions, No. 512, IV-27. *Proceedings of the Japan Society of Civil Engineering*, 61-71.
59. Hupfer, C. (1997). Deceleration to safety time (DST) - a useful figure to evaluate traffic safety. *Proceedings of the ICTCT Conference*. Department of Traffic Planning and Engineering, Lund University, Sweden.
60. Chan, C.-Y. (2006). Defining safety performance measures of driver-assistance systems for intersection left-turn conflicts. *Proceedings of the IEEE Intelligent Vehicles Symposium*. Tokyo, Japan, 25-30.
61. Cunto, F.J.C.; and Saccomanno, F.F. (2007). Microlevel traffic simulation method for assessing crash potential at intersections. *Proceedings of the Transportation Research Board 86th Annual Meeting*. Washington, D.C., United States of America.
62. Hiraoka, T.; Tanaka, M.; Kumamoto, H.; Izumi, T.; and Hatanaka, K. (2009). Collision risk evaluation index based on deceleration for collision avoidance (First Report). Proposal of a new index to evaluate collision risk against forward obstacles. *Review of Automotive Engineering*, 30(4), 429-437.

63. van Arem, B.; de Vos, A.; and Vanderschuren, M. (1997). *The effect of a special lane for intelligent vehicles on traffic flows*. An explanatory study using microscopic traffic simulation model MIXIC. TNO (44). Department of Traffic and Transport, The Netherlands.
64. af Wåhlberg, A.E. (2000). The relation of acceleration force to traffic accident frequency: A pilot study. *Transportation Research Part F: Traffic Psychology and Behaviour*, 3(1), 29-38.
65. Vogel, K. (2003). A comparison of headway and time to collision as safety indicators. *Accident, Analysis and Prevention*, 35(3), 427-433.
66. Aron, M.; Biecheler, M.; and Peytavin, J. (2002). Temps intervehiculaires et vitesses: Quels enjeux de securite sur les routes de Normandie? Premiere etape: Realisation du recueil de donnees et description des indicateurs. *Proceedings of the Rapport Sur Convention Inrets/Dscr*. Institut National de Recherche sur les Transports et leur Securite (INRETS). Germany.
67. Hironori, S.; and Takashi, N. (2004). Effect of adaptive cruise control (acc) on traffic throughout a numerical example on actual freeway corridor. *Transactions of Society of Automotive Engineers of Japan*, 35(1), 239-245.
68. Isaji, K.; Tsuru, N.; Wada, T.; Imai, K.; Doi, S.; and Kaneko, H. (2007). Emergency evaluation by approaching in longitudinal direction (first report). Proposal of performance index for approach and alienation based on the driver operations. *Transactions of Society of Automotive Engineers of Japan*, 38(2), 25-30.
69. Isaji, K.; Tsuru, N.; and Morikawa, S. (2009). A method to adapt. "Judgement line of brake initiation" to individual drivers. *Review of Automotive Engineering*, 30(3), 313-320.
70. Shariat-Mohaymany, A.; Tavakoli-Kashani, A.; Nosrati, H.; and Ranjbari, A. (2011). Identifying significant predictors of head-on conflicts on two-lane rural roads using inductive loop detectors data. *Traffic Injury Prevention*, 12(6), 636-641.
71. Guido, G.; Astarita, V.; Giofre, V.; and Vitale, A. (2011). Safety performance measures: a comparison between microsimulation and observational data. *Procedia-Social and Behavioral Sciences*, 20, 217-225.
72. Ismail, K.; Sayed, T.; and Saunier, N. (2011). Methodologies for aggregating indicators of traffic conflict. *Transportation Research Record: Journal of the Transportation Research Board*, 2237, 10-19.
73. Salamati, K.; Shroeder, B.; Roupail, N.M.; Cunningham, C.; Long, R.; and Barlow, J. (2011). Development and implementation of conflict-based assessment of pedestrian safety (CAPS) to evaluate accessibility of complex intersections. *Transportation Research Record: Journal of the Transportation Research Board*, 2264, 148-155.
74. Bagdadi, O. (2013). Assessing safety critical braking events in naturalistic driving studies. *Transportation Research Part F: Traffic Psychology and Behaviour*, 16, 117-126.
75. Berthelot, A.; Tamke, A.; Dang, T.; and Breuel, G. (2012). A novel approach for the probabilistic computation of time-to-collision. *Proceedings of the IEEE Intelligent Vehicles Symposium*. Alcalá de Henares, Spain, 1173-1178.

76. American Association of State Highway Transportation Officials (AASHTO). (2011). *A policy on geometric design of highways and streets*. United States of America: AASHTO.
77. Farah, H.; Bekhor, S.; and Polus, A. (2008). A model for passing decisions on two-lane rural highways. *Proceedings of the Transportation Research Board 87th Annual Meeting*. Washington D.C., United States of America.
78. Hegeman, G. (2008). *Assisted overtaking: an assessment of overtaking on two-lane rural roads*. Ph.D. Thesis. Civil Engineering and Geosciences, Delft University of Technology, Delft, Netherlands.
79. Shbeeb, L. (2000). *Development of traffic conflicts technique for different environments: A comparative study of pedestrian conflicts in Sweden and Jordan*. Ph.D. Thesis. Department of Technology and Society, Lund University, Lund, Sweden.
80. Michael, P.G.; Leeming, F.C.; and Dwyer, W.O. (2000). Headway on urban streets: Observational data and an intervention to decrease tailgating. *Transportation Research Part F: Traffic Psychology and Behaviour*, 3(2), 55-64.
81. Hydén, C. (1996). *Traffic conflicts technique: State-of-the-art*. Department of Traffic Planning and Engineering, Lund Institute of Technology, Lund, Netherlands.
82. Topp, H. (1998). Traffic safety work with video-processing. *Green Series No. 43*. Transportation Department, University Kaiserslautern, Kaiserslautern, Germany.
83. Kraay, J.H.; van der Horst, A.R.A.; and Oppe, S. (1986). *Handleiding voor de conflictobservatietechniek doctor. Dutch objective conflict technique for operation and research. Deel I. Methode en toepassingsbereik. Deel II. Trainen met de doctor-techniek*. Leidschendam: SWOV.
84. Archer, J. (2005). *Indicators for traffic safety assessment and prediction and their application in micro-simulation modelling: A study of urban and suburban intersections*. Ph.D. Thesis. Department of Infrastructure, Royal Institute of Technology, Stockholm, Sweden.
85. Songchitruksa, P.; and Tarko, A.P. (2006). Practical method for estimating frequency of right-angle collisions at traffic signals. Transportation Research Record. Transportation Research Board of the National Academies, Washington D.C. *Journal of the Transportation Research Board*, 1953(1), 89-97.
86. American Association of State Highway Transportation Officials (AASHTO) (2004). *A policy on geometric design of highways and streets* (5th edition). United States of America: AASHTO.
87. Guido, G.; Saccomanno, F.; Vitale, A.; Astarita, V.; Demetrio. (2010). Comparing safety performance measures obtained from video capture data. *Journal of Transportation Engineering*, 137(7), 481-491.
88. Williams, M.J. (1981). Validity of the traffic conflicts technique. *Accident Analysis & Prevention*, 13(2), 133-145.
89. Tiwari, G.; Mohan, D.; and Fazio, J. (1998). Conflict analysis for prediction of fatal crash locations in mixed traffic streams. *Accident Analysis & Prevention*, 30(2), 207-215.
90. Guttinger, V. (1982). From accidents to conflicts: alternative safety measurement. *Proceedings of the Third International Workshop on Traffic Conflict Techniques ICTCT*. Institute for Road Safety Research (SWOV), The Netherlands, 98 pages.

91. Young, W.; Sobhani, A.; Lenne, M.G.; and Sarvi, M. (2014). Simulation of safety: A review of the state of the art in road safety simulation modelling. *Accident Analysis & Prevention*, 66C, 89-103.
92. Cunto, F.J.C. (2008). *Assessing safety performance of transportation systems using microscopic simulation*. Ph.D. Thesis. Civil and Environmental Engineering, University of Waterloo, Ontario, Canada.
93. Khan, S.; and Maini, P. (1999). Modeling heterogeneous traffic flow. Transportation Research Record: *Journal of the Transportation Research Board*, 1678, 234-241.
94. Muhlrad, N. (1982). The French traffic conflict technique: a state of the art report. *Proceedings of the Third International Workshop on Traffic Conflicts Techniques*. Institute for Road Safety Research (SWOV), The Netherlands.
95. Almqvist, S.; and Hydén, C. (1994). *Methods for assessing traffic safety in developing countries*. Lund Centre of Habitat Study, Lund University. Building Issues, 6(1), 20 pages.
96. Hydén, C.; and Linderholm, L. (1984). The Swedish traffic-conflicts technique. *Proceedings of the NATO Advanced Research Workshop on International Calibration Study Traffic Conflict*. Copenhagen, Germany, 133-139.
97. Buddhharaju, R.; Jha, M.K.; Kang, M.-W.; and Raju, P.M. (2013). Predicting road accidents and prioritizing road safety improvement measures in developing countries using adapted traffic conflict techniques. *Proceedings of the Transportation Research Board 92nd Annual Meeting*. Washington, D.C., United States of America.
98. Vedagiri, P.; and Killi, D.V. (2015). Traffic safety evaluation of uncontrolled intersections using surrogate safety measures under mixed traffic conditions. Transportation Research Record. *Journal of the Transportation Research Board*, 2512, 81-89.
99. Gettman, D.; and Head, L. (2003). Surrogate safety measures from traffic simulation models. Transportation Research Record: *Journal of the Transportation Research Board*, 1840, 104-115.
100. Petermans, A.; Gysen, G.; Jong, M.; and Daniels, S. (2009). *Handbook Swedish traffic conflict measuring technique*. Policy Research Centre Traffic Safety, University of Hasselt, Wetenschapspark 5 B 3590 Diepenbeek, Belgium.
101. Taieb-Maimon, M.; and Shinar, D. (2001). Minimum and comfortable driving headways: Reality versus perception. *Human Factors: The Journal of the Human Factors and Ergonomics Society*, 43(1), 159-172.
102. Bin, M. (2003). A study of lane-changing behavior model at weaving section considering conflicts. *Journal of the Eastern Asia Society for Transportation Studies*, 5, 2039-2052.
103. Qu, X.; Kuang, Y.; Oh, E.; and Jin, S. (2014). Safety evaluation for expressways: a comparative study for macroscopic and microscopic indicators. *Traffic Injury Prevention*, 15(1), 89-93.
104. Tarko, A.P. (2012). Use of crash surrogates and exceedance statistics to estimate road safety. *Accident Analysis & Prevention*, 45, 230-240.
105. Farah, H.; Bekhor, S.; and Polus, A. (2009). Risk evaluation by modeling of passing behavior on two-lane rural highways. *Accident Analysis & Prevention*, 41(4), 887-894.