

ANTI-VIBRATION SLAB MAT TO SUPPRESS TRAIN TRACK VIBRATIONS

CHAN JAY REN¹, MOHAMMAD HOSSEINI FOULADI^{1,*},
SATESH NARAYANA NAMASIVAYAM¹, HON HUI JUEN¹,
CHARALAMPOS BANIOTOPOULOS², MILES RICHARD TIGHT²,
SAKDIRAT KAEWUNRUEN²

¹School of Engineering, Taylor's University, 47500 Subang Jaya, Selangor, Malaysia

²School of Engineering, University of Birmingham, B15 2TT, Birmingham, United Kingdom

*Corresponding Author: mfoolady@gmail.com

Abstract

The purpose of this study is to discover the correlation between anti-vibration slab mat mechanical characteristics and vibration isolation performance. When the train accelerates on the track, the train movement and static load propagate together, thus transforming the static load to a dynamic load. The transformation is caused by imbalance in between the rail surface and wheel. Anti-vibration slab mat is located among the concrete layers of slab track. In order to acquire the optimum designation of slab mat, optimization process was conducted by utilizing elastic element, which consists of excellent mechanical attributes. Numerical analysis was performed on a 3D model track-bridge structure, which was produced in SolidWorks by using the modal parameters acquired from literature review. Meshing using body sizing was performed. Next, the modal and harmonic response analysis were subjected to a suitable boundary condition setup. A frequency response graph of bridge acceleration was acquired from harmonic response analysis for different modal parameters of slab mat. In addition, a prelude outcome illustrated the efficiency of slab mat layer composed of synthetic rubber in minimizing vibration. To sum up the study, the mechanical attributions of anti-vibration slab mat, which is great damping ratio, less stiffness and expanded thickness are contributing factors to the minimization of bridge acceleration.

Keywords: Anti-vibration slab mat, Harmonic load, High-speed railway, Rubber, Train track vibration.

1. Introduction

Railway transportation is vital and provides an extensive connection within suburban and commercial zones, which is a huge benefit. The subway trains emit ground-borne vibrations, which is a huge problem as people and building structures are influenced by it [1]. Transportation systems produce sound and vibration due to the train track vibrations and these vibrations emitted travel to surrounding buildings through the tunnel construction and soils. Constant vibrations could cause damage and harm to the building material even though the vibrations are normally low [2]. In the surroundings areas of railway traffic, human will be affected by airborne noise and structural vibrations. They will experience discomfort which is caused by vibrations or noise produced by structural vibrations, called structural borne sound, that led the surface to radiate [3].

The wheel or rail interconnection point is the place where operational rail vibration emerges and propagates to the tunnel construction, ground and nearby infrastructures through the track support system. The vibrations induced by the trains operating in tunnels has a usual frequency that range from 4 Hz to thousands Hz [4]. The transmission of the weight of trains is from the wheel to rail, which is then reallocated, by the rail, track structure and ground and this is known as static load. As the train accelerates on the track, this force moves alongside with the train motion. The distinction at different parts of the train-track structure system, for example the non-uniform rail and wheel surface, and also the dissimilarities in the support structure underneath the rail will transform the static load to a dynamic load.

In order to segregate the supporting base from the train structure and decrease the conveyance of vibration from the train track, anti-vibration slab mat is usually situated and positioned between the concrete layers. The core function of anti-vibration slab mat is to suppress the vibrations emitted by the train, which is done by separating the soil from the buildings as the anti-vibration slab mat functions as a soft layer of foundation mat for buildings [2]. Because of the installation of an elastic slab mat beneath the slab, a low natural frequency is obtained by the system of the track and as for frequencies that is greater than the low track natural frequency, the reduction of force, which produces the soil vibration, is done [5]. By doing so, the track performance can be enhanced and issues generated from high-speed train traffic can be solved.

In addition, two mechanical attributes will influence the performance for vibration isolation of the anti-vibration slab mat. These are the damping coefficient followed by stiffness which relies on the mechanical attributes of the rubber elements utilized [1]. Hence, the anti-vibration slab mat should possess low stiffness and high damping coefficient for the purpose of enhancing the effectiveness for vibration reduction [6]. The most suitable material to be utilized for the slab mat is natural rubber, this is because it has a smaller ratio of dynamic to static stiffness, and can also sustain for a longer period. In addition to that, it shows insignificant indications of deterioration or transformation in the mechanical characteristics [7]. Mechanical energy dissipation and deformation capacity are examples of other characteristics that rely on the density, degree of thickness, sizes and type of compounds the mat is formed of. Generally, the thickness of the mats will range from 15 to 30 mm, and its horizontal dimensions are determined by the methods evolved in the construction period [8].

The purpose of this study is to overcome vibration problems by determining the ultimate designation of anti-vibration slab mat. The 3D model produced in SolidWorks was replicated to perform numerical analysis in ANSYS in order to examine the performance of slab mat vibration minimization. Furthermore, modal and harmonic responses were included in the ANSYS analysis. A calculation was done on the frequency response graphs, which were affected by harmonic loading. Next, the outcomes acquired were in a graph format, which contains response quantity such as velocity, displacement or acceleration subjected to a prescribed range of frequency. To determine the ideal designation for an anti-vibration slab mat, a smaller degree of vibration response has to be acquired through manipulation of the modal parameters based on the results obtained.

2. Research Methods

2.1. Design of anti-vibration slab mat

In the design process of anti-vibration slab mat, it involved the use of CAD software, which was SolidWorks before importing the design for numerical analysis in ANSYS Workbench. The details of the design were discussed in the following section.

Geometrical modelling

Firstly, CAD, SolidWorks was used to produce 3D track-bridge model as shown in Fig. 1. This model was referred to the layout of slab track with slab mat layer and bridge sketch used by T. Xin and L. Gao [9] to interpret dynamic relations among high-speed railway, running at 350 km/hr and the bridge. The model comprises of rail, rail pad, slab and bridge body. Located in between the concrete slab and bridge body was the anti-vibration slab mat. In addition, the model was originated from the mid-span area, which was the prime span of the 48 m length bridge. Nevertheless, for the aim of reducing computing time and complexity in numerical simulation, merely train track of 1 m length was taken into account for the analysis. A half-track-bridge model of 1400 mm width could be simplified from a full track-bridge model as shown in Figs. 2 and 3 due to the symmetrical property of geometry.

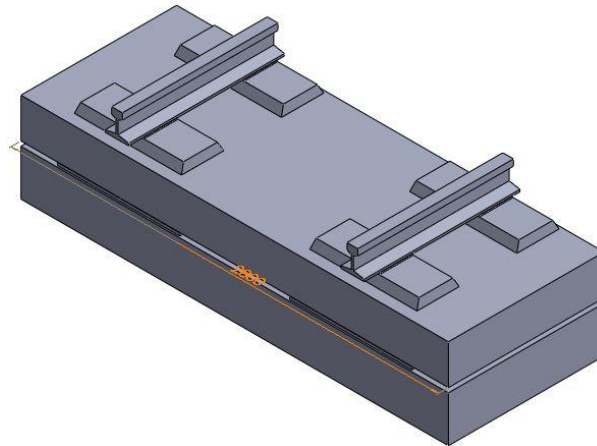

Fig. 1. Isometric view of full track-bridge model.

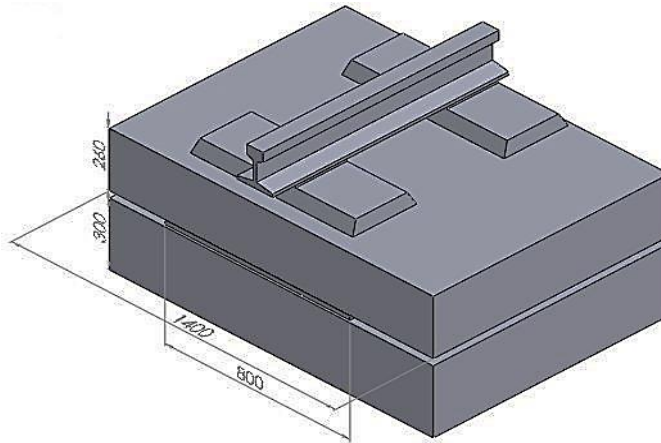

Fig. 2. Isometric view of the half-track-bridge model in mm scale.

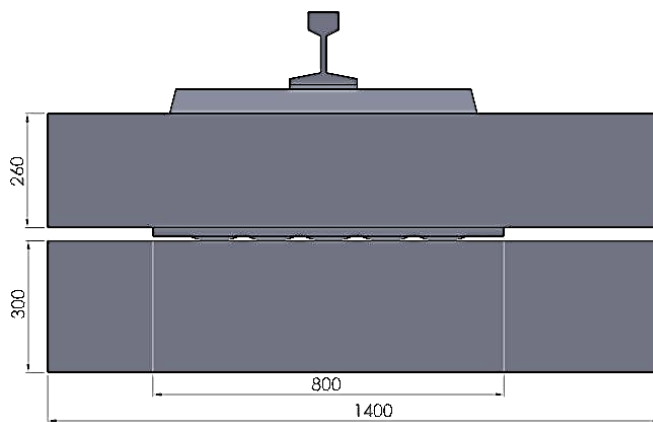

Fig. 3. Front view of the half-track-bridge model in mm scale.

The thickness was set at 30 mm with 800 mm x 1020 mm area for the designation of anti-vibration slab mat. Based on Fig. 4, the designation also consists of conical studs of 10 mm thickness on a mat surface. The material used to manufacture the conical studs was of synthetic rubber or natural rubber, which has a function similar to a spring with an ideal ratio of dynamic to static stiffness. Besides that, the assisting layer for the studs was constituted with the back of 20 mm thickness, whereas the composite materials serves as a damping and protective layer, which was able to sustain slab track, loads. Vibrations from railway could be minimized due to the excellent characteristics of rubber with the conical shape of the studs increasing the rubber's efficiency. The cone will disfigure into a hemisphere under pressure of load and the hemisphere shape was able to virtually reach uniform natural frequency for the range of loads. Conical studs has a compression set which is a measure of existing disfiguration, they were very tiny in that and thus, their dynamic efficiency was not affected in the long run.

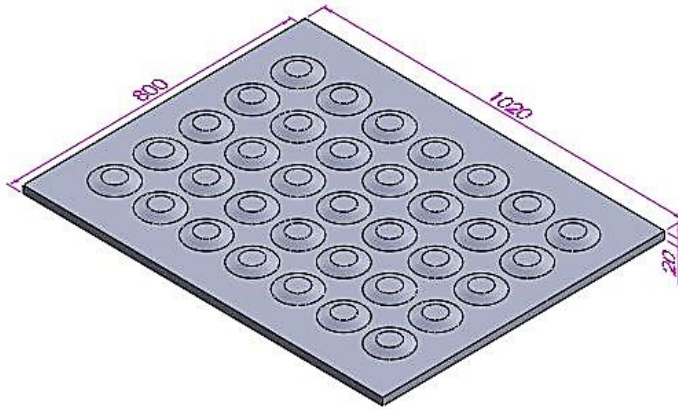

Fig. 4. 3D model of anti-vibration slab mat in SolidWorks with units of mm.

2.2. Numerical analysis

In numerical analysis, meshing was performed on the 3D half-track-bridge model before subjecting it to a boundary condition setting. The material properties were also mentioned and they were used to perform a two-step analysis which was modal analysis followed by harmonic response analysis. The settings of the analysis were also included in the section below.

2.2.1. Meshing

Body sizing was opted for the 3D model. In order to assure excellent standard of mesh, an evaluation was done on the element quality and skewness of the mesh. The ultimate ideal method for mesh is MultiZone method as it required less elements to discretize the model, it also contained the greatest element quality and minimum skewness. Hence, a greater accuracy of outcome and a rapid estimation can be achieved. Figure 5 shows the meshed model using MultiZone method.

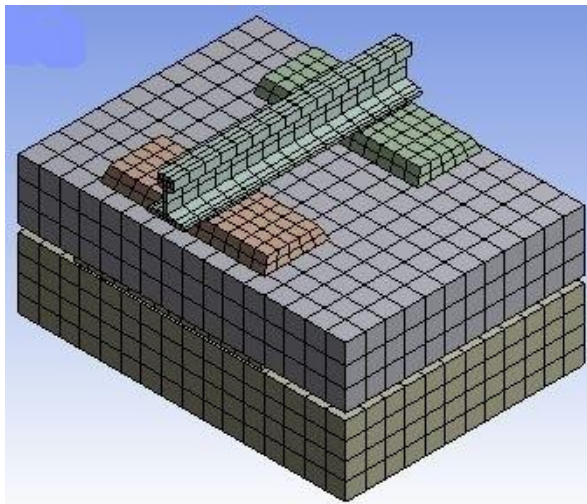

Fig. 5. Meshing of 3D model using MultiZone method.

2.2.2. Setting of boundary conditions

After allocating the material properties for every component in ANSYS engineering data, as depicted in Table 1, the numerical analysis was set to Modal. The material properties of natural rubber and synthetic rubber were referred to the Material Data Book of Cambridge University Engineering Department [10]. The engineering data library in ANSYS also contains structural steel and concrete material properties. The ratio of Poisson's was 0.45 and 0.495 for synthetic rubber and natural rubber consecutively, based on [1]. A fixed support was set at the bridge body, which was the base of the model's lowest layer. Next, a variation of mode shapes and natural frequencies of model were produced and replicated.

Harmonic response analysis was conducted upon completion of the modal analysis. The high-speed railway produces 119700 N of wheel-rail force, which operates on the rail beam. Since the 3D model was modelled as half-track-bridge model, the vertical force applied on the rail beam surface was reduced to 59850 N. The boundary condition set for the analysis was shown in Fig. 6.

Table 1. Material properties for all components in the 3D model [1, 10].

Components	Material	Density, ρ (kg/m ³)	Young's Modulus, E (GPa)	Poisson's Ratio, ν
Rail	Structural Steel	7850	200	0.30
Rail Pad	Natural Rubber	920	0.0025	0.495
Slab	Concrete	2300	30	0.18
Slab Mat	Butyl Rubber	900	0.001	0.45
Bridge Body	Concrete	2300	30	0.18

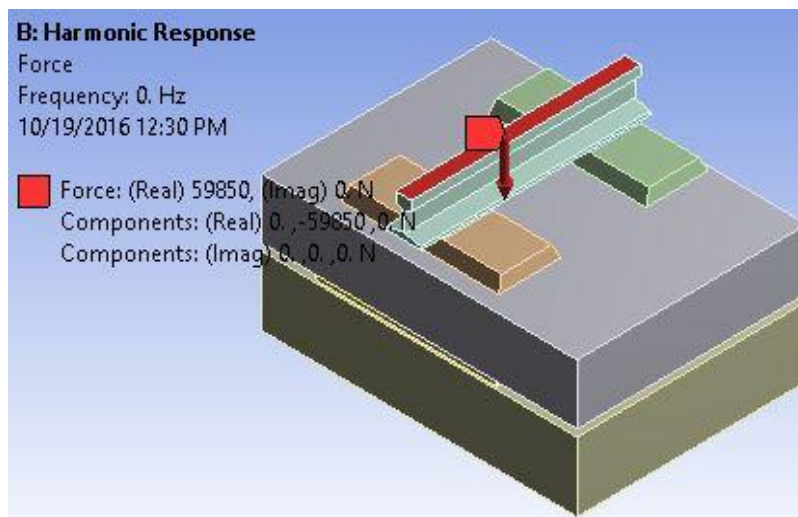

Fig. 6. Boundary condition applied on the track-bridge model.

2.2.3. Modal analysis

Modal analysis is defined as the method to investigate the dynamic properties between the bridge and the track, which is influenced by excitations of vibrations. Modal analysis can also be used to discover the mode shapes and natural frequencies of the composition. One of the advantages of utilizing ANSYS is the availability of precise visualization and simulation of the mode shapes, thus enable distortions of the track bridge model to be accurately detected.

ANSYS Workbench was used to determine frequency against graphical distinction of number of modes. The greatest number of modes was fixed at 10 for the analysis setting. Therefore, there will be 10 different mode shapes with their respective natural frequencies being generated.

2.2.4. Harmonic response analysis

The function of harmonic analysis is to discover the steady state response of a linear structure to loads, which differs sinusoidally with time. Harmonic analysis does not include the transient vibrations, which take place at the starting of stimulation. This allows validation on the situations in which the designs are able to conquer problems such as resonance, fatigue and destructive consequences caused by forced vibrations.

The necessary input properties in harmonic analysis were density, Young's modulus and Poisson's ratio. Next, the analysis of harmonic response can be conducted as soon as the operation of modal analysis was done. The reason for this was that modal coordinates from the modal analysis were utilized. To enhance the efficiency of harmonic analysis, a harmonic solution with the Mode Superposition technique was used. The frequency consists of 10 intervals with a range of 0 to 200 Hz. This showed that simulation was able to resolve for 10 exciting frequencies of 20, 40, 60, 80, 100, 120, 140, 160, 180 and 200 Hz. A constant damping ratio of 1 % was set under the damping control of the analysis.

A graph of certain response quantity for example displacements and acceleration against frequency can be obtained through a standard harmonic analysis, which is able to measure the structure response to cyclic loads over a range of frequency (sine sweep). This allows for "peak" responses to be determined from these graphs of response against frequency.

3. Results and Discussion

Modal and harmonic response analyses were performed in ANSYS Workbench to obtain frequency response graph for bridge acceleration. The simulations were repeated for different stiffness, damping ratio and thickness of slab mat. The results obtained were plotted into graphs in Excel to show the relationship between different parameters of slab mat and its vibration reducing effect.

3.1. Impact of anti-vibration slab mat in reducing vibration

To investigate the effect of minimizing vibrations, bridge acceleration was chosen as the indicator to show the changes caused by minimizing vibrations. 23.5 Hz was the frequency of excitation used in this study. Comparison and evaluation were performed for two conditions, slab track with slab mat layer, followed by slab mat without slab

mat layer. Results in Fig. 7 showed that the slab mat layer was able to reduce the bridge acceleration and maintained at a minimal acceleration close to 0.01 ms^{-2} as frequency increased. However, for slab track with no insertion of slab mat layer, the bridge acceleration kept increasing and reached a maximum value of approximately 4 ms^{-2} . Since the acceleration of the bridge is high, the vibration amplitude is greater as well. Therefore, to reduce vibrations transmission to surrounding infrastructures from the bridge, high-speed railway must contain slab mat layer.

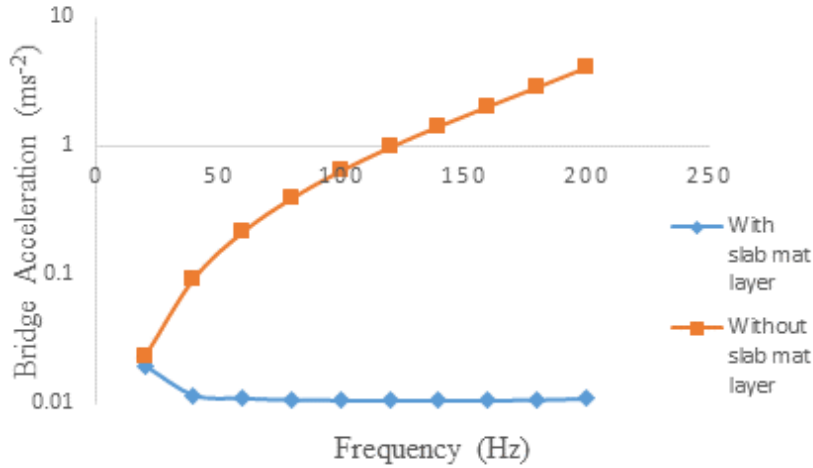

Fig. 7. Bridge acceleration against frequency graph for slab track with and without slab mat layer.

3.2. Impact of slab mat stiffness

The stiffness of elastic elements has a huge influence in minimizing vibrations produced by railway track. Synthetic rubber, acquired from worn tyres or recycled rubber was the elastic element utilized by the anti-vibration slab mat [1]. Besides that, butyl rubber with elastic modulus, E of 1.0 MPa acts as the elastomer. The stiffness of element varies accordingly to the elastic modulus based on the formula of $k = \frac{AE}{l}$. Neoprene, an elastomer with 0.7 MPa elastic modulus was used to examine dynamic response of a railway track by manipulating the slab mat stiffness from greater value to smaller value. The lower the elastic modulus, the lesser the stiffness.

According to Fig. 8, a great reduction of accelerations on bridge was observed when the frequencies were less than 50 Hz . By using a neoprene slab mat, bridge acceleration can be minimized to 0.01 ms^{-2} at low frequency of 20 Hz . Conclusively, in comparison to butyl rubber slab mat, neoprene slab mat with a lower stiffness is greater in terms of efficiency. Furthermore, to effectively minimize the levels of vibration, lower stiffness mat is much preferable for it to cut down stresses acting on track and also force transmission from harmonic load.

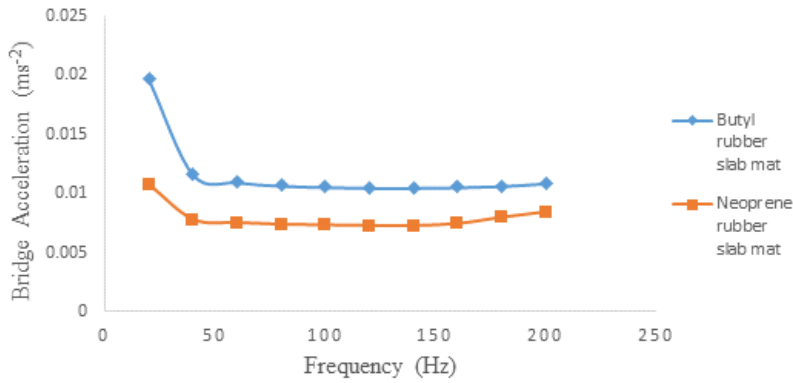

Fig. 8. Bridge acceleration against frequency graph for slab track using two different types of material and stiffness for the slab mat layer.

3.3. Impact of slab mat damping ratio

The damping ratio of material utilized for slab mat is another important factor for minimizing vibration originated from train track. Mechanical energy can be converted to heat through damping. Thus, overall mechanical energy will reduce as it goes through material damping. Constant damping ratio was increased from 1 % up to 10 %.

Performance of butyl and neoprene slab mat were analysed with greater damping ratio value and results were shown in Fig. 9. It can be seen that as damping ratio for both butyl and neoprene increases, the acceleration of bridge reduces. The fall in the response for train vibration was not notable, probably because of the non-significant increase in damping ratio. Hence, to allow efficient absorption of vibration by slab mat and elimination of vibrational energy on the bridge, damping ratio has to be increased to a greater amount.

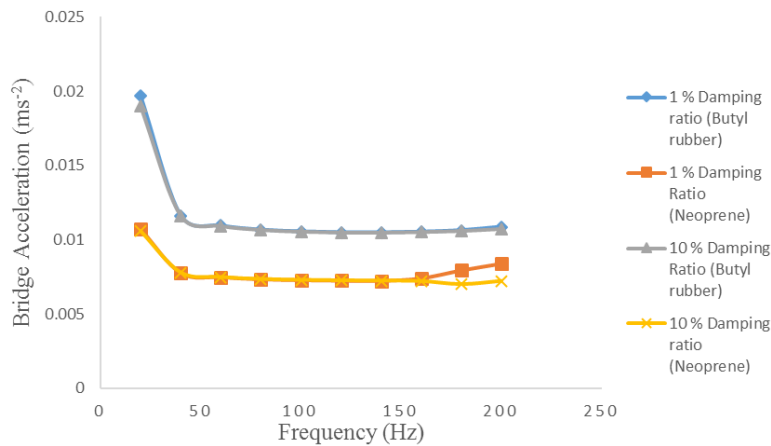

Fig. 9. Bridge acceleration against frequency graph for slab track using two different types of material and damping ratio for the slab mat layer.

3.4. Impact of slab mat thickness

The changes caused by minimizing vibration could be seen by manipulating the slab mat thickness from 25 mm to 35 mm, in which 30 mm was the starting thickness value of slab mat. An observation of performance reduction for butyl rubber and neoprene slab mat can be seen when bridge acceleration increases, this was due to the 5 mm decrement for thickness. Besides, when bridge acceleration decreases, butyl rubber and neoprene slab mat efficiency was enhanced, this was due to the increment of 5 mm on thickness of slab mat. Nevertheless, provided with similar thickness, neoprene slab mat has better vibration isolation characteristic when compared to butyl rubber mat. Based on Fig. 10, vertical vibration transmitted from railway track could be minimized when slab mat thickness was increased. Hence, a slab mat with greater thickness is able to take in greater impact, dampen the vibration and also reduces the constant repetition vibration's impact, which will ultimately cause damage to bridge structure.

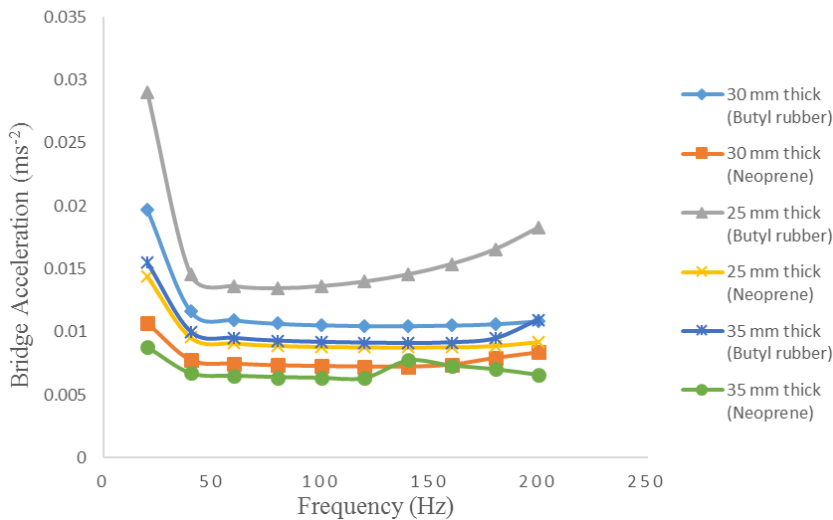

Fig. 10. Bridge acceleration against frequency graph for slab track using two different types of material with varying thickness of slab mat layer.

4. Conclusions

In conclusion, the design of anti-vibration slab mat was produced in SolidWorks and simulated in ANSYS Workbench. Different modal parameters of slab mat such as material, stiffness, damping ratio and thickness were analysed to demonstrate the effect of vibration reduction on the track-bridge model. Two types of analysis, which were modal and harmonic response, were required for the numerical simulation. To ensure higher efficiency of simulation and more accurate results, proper meshing was done using MultiZone method with body sizing due to its high element quality and low skewness values. Results were then obtained from the frequency response graphs of acceleration in harmonic analysis after completing modal analysis. From the results, the bridge acceleration was decreased when slab

mat layer was applied in the track-bridge model due to its ability to absorb impact of harmonic load exerted along the train track.

In numerical simulation, the acceleration of bridge of the track-bridge model was analysed with changing parameters of anti-vibration slab mat. Results showed that neoprene rubber with lower stiffness performs better than butyl rubber for the same damping ratio and thickness. Furthermore, when damping ratio and thickness of slab mat using neoprene rubber were increased from 1 % to 10 % and 30 mm to 35 mm respectively, the bridge acceleration decreases which shows a positive result in vibration reducing effect. Hence, optimization on the physical property of slab mat using neoprene rubber should be carried out for further analysis. The results acquired will be analysed using vibration nomograph to identify the acceptable vibration levels for human comfort.

Nomenclatures

a	Acceleration of bridge, m/s
E	Young's modulus, GPa
f	Frequency of excitation, Hz
k	Stiffness of slab mat's material, N/m
t	Thickness of slab mat, mm

Greek Symbols

ν	Poisson's ratio
ρ	Density of slab mat's material, kg/m ³
ζ	Constant damping ratio of slab mat, %

Abbreviations

3D	Three-Dimensional
CAD	Computer-Aided Design

References

1. Montella, G.; Mastroianni, G.; and Serino, G. (2012). Experimental and numerical investigations on innovative floating-slab track including recycled rubber elements. *Proceedings of ISMA2012-USD2012*. Naples, Italy, 2869-2880.
2. Hildebrand, R. (2001). *Countermeasures against railway ground and track vibrations*. Ph.D. dissertation. Department of Vehicle Engineering, Royal Institute of Technology, Stockholm, Sweden.
3. Rantatalo, M.; and Tao, X. (2013). *Review of countermeasures and regulations for railway induced ground vibrations in tunnels*. Lulea University of Technology and Lulea Railway Research Center JVTC, Rep.
4. Hemsworth, B. (2000). Reducing ground borne vibrations: state-of-the-art study. *Journal of Sound and Vibration*, 231(3), 703-709.
5. De Roeck, G.; Degrande, G.; Lombaert, G.; and Muller, G. (2011). The dynamic force transfer of slab tracks and floating slab tracks and the

- corresponding ground vibration. *Proceedings of the 8th International Conference on Structural Dynamics*. Leuven, Belgium, 820-827.
6. Esveld, C. (2001). *Modern railway track*. MRT-Productions, Netherlands.
 7. Wilson, G.P. (2004). Rail system noise and vibration control. *Proceedings of ACOUSTICS 2004*. Gold Coast, Australia, 1-9.
 8. Sol-Sanchez, M.; Moreno-Navarro, F.; and Rubio-Gamez, M.C. (2015). The use of elastic elements in railway tracks: A state of the art review. *Construction and Building Materials*, 75, 293-305.
 9. Xin, T.; and Gao, L. (2011). Reducing slab track vibration into bridge using elastic materials in high speed railway. *Journal of Sound and Vibration*, 330(10), 2237-2248.
 10. Cambridge University Engineering Department. (2003). Materials data book. Retrieved May 28, 2018, from <http://www-mdp.eng.cam.ac.uk/web/library/enginfo/cueddatabooks/materials.pdf>.